

X160 High Head Explosion Proof Effluent Pump Series

Commercial Sump and Effluent Pump

Submersible effluent or De-watering pumps with explosion-proof motors.

Features:

- cCSAus rated Class I, Division 1, Groups C & D and Class Zone 1, Groups IIA & IIB gas areas or Class II, Division 1, Groups E, F and G and Zone 20 dust areas
- Tested to FM standards 3600 and 3615 by CSA
- Non-clogging vortex impeller design
- Durable, cast construction: cast iron cover, motor adapter and pump housing. All cast iron class 30, 30000# tensile strength
- 1 year limited warranty

100% factory tested



FM3407
0222
Supersedes
1221

Trusted. Tested. Tough.®

zoellerpumps.com 800-928-7867
3649 Cane Run Road, Louisville, KY 40211 USA

X160 High Head Explosion Proof Effluent Pump Series

MOTOR	Horse Power	1/2 (X161, X163) or 1 (X165)
	Voltage	115 - 575
	Phase	1 or 3 Ph
	Hertz	60 Hz
	RPM	3450
	Type	Permanent split capacitor or 3 Ph
	Insulation	Class B
Amps	2.4 - 15.5	
PUMP	Operation	Automatic or nonautomatic
	Auto On/Off Points	19-1/2" (495 mm) / 10" (25.4 cm)
	Discharge Size	1-1/2" NPT (optional 2" or 3" flange)
	Solids Handling	3/4" (19 mm) spherical solids
	Cord Length	20' (6 m) standard
	Cord Type	UL listed 5-wire (1 Ph) or 8-wire (3 Ph) SOOW
	Max. Head	86.5' (26 m)
	Max. Flow Rate	100 GPM (379 LPM)
	Max. Operating Temp.	104 °F (40 °C)
	Cooling	Oil filled
	Motor Protection	Auto reset thermal overload (1 Ph) or thermal sensor (3 Ph)
MATERIALS	Upper Bearing	Ball bearing
	Lower Bearing	Ball bearing
	Mechanical Seals	Carbon and ceramic with stainless steel parts
	Impeller Type	Non-clogging vortex
	Impeller	Cast iron, optional bronze
	Hardware	Stainless steel
	Motor Shaft	416 stainless steel
Gasket	Neoprene square rings	

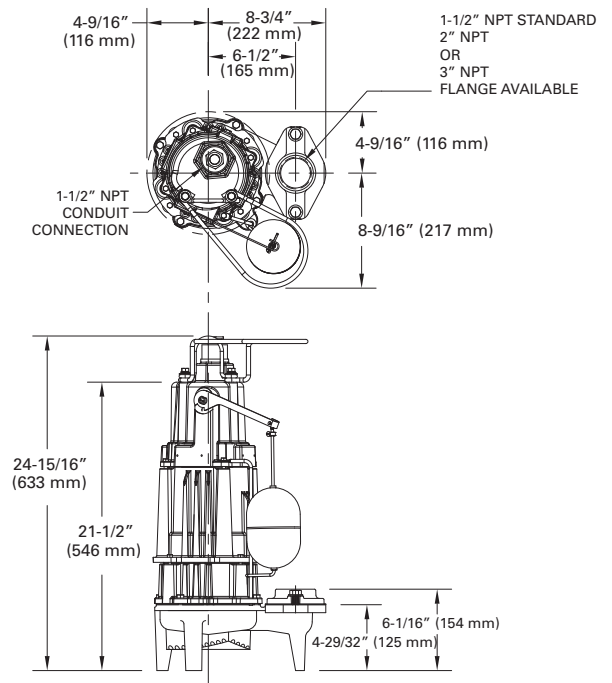

Automatic

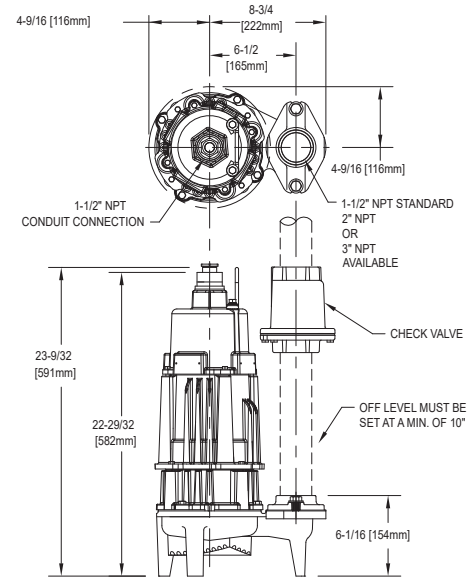

Nonautomatic

* no molded plug (1) cCSAus approved unit available with 20 Amp plug. (2) CSA approved unit with 15 Amp plug.

Additional cords lengths are available in 25' (8 m), 35' (11 m), and 50' (15 m).

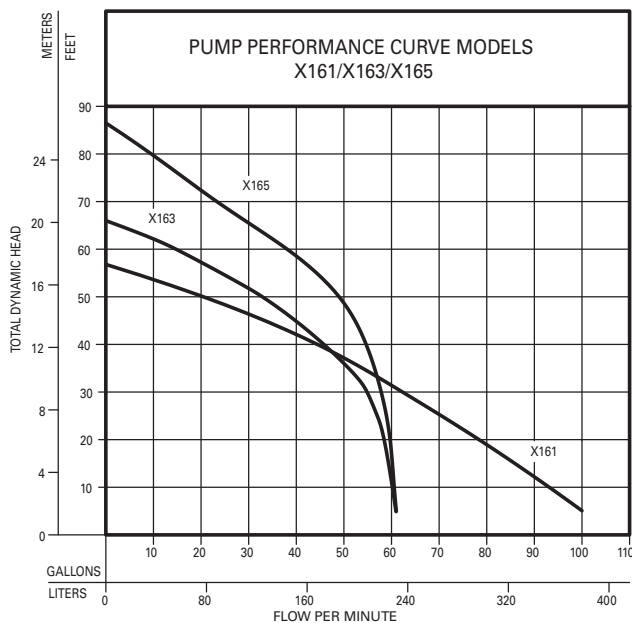

009920

