

Your Peace of Mind is Our Top Priority®

FM1469

0413

Supersedes

1209

Product information presented here reflects conditions at time of publication. Consult factory regarding discrepancies or inconsistencies.



PUMP COMPANY

Zoeller Family of Water Solutions™

MAIL TO: P.O. BOX 16347 • Louisville, KY 40256-0347
 SHIP TO: 3649 Cane Run Road • Louisville, KY 40211-1961
 (502) 778-2731 • 1 (800) 928-PUMP • FAX (502) 774-3624

visit our web site:
www.zoeller.com

MODEL NO. _____
DATE CODE: _____
DATE INSTALLED: _____



Model 103 is not IAPMO approved.

QWIK JON® 100/101/102/103 SYSTEMS INSTALLATION INSTRUCTIONS PREINSTALLATION CHECKLIST

Patent No. 5,038,418

1. Inspect all materials. Occasionally, products are damaged during shipment. If the unit is damaged, contact your dealer before using. **Do Not** remove the test plugs from the pump.
2. Carefully read all the literature provided to familiarize yourself with specific details regarding installation and use before attempting the installation. These materials should be retained for future reference.



WARNING

SEE BELOW FOR LIST OF WARNINGS

1. **To help reduce the risk of electrical shock**, a properly grounded receptacle or control box of grounding type must be installed and protected by a ground fault circuit interrupter (GFCI) in accordance with the National Electrical Code and applicable local codes. **Never remove ground pin from plug.** If pump is wired direct, a GFCI must be installed in the control box. (SEE WARNING BELOW)
2. Make certain that the ground fault interrupter protected receptacle or control box is within reach of the pump's power supply cord. **DO NOT USE AN EXTENSION CORD.** Extension cords that are too long or too light do not deliver sufficient voltage to the pump motor. But more important, they could present a safety hazard if the insulation were to become damaged or the connection end were to fall into a damp or wet area.
3. **Make sure the pump's electrical supply circuit is equipped with fuses or circuit breakers of proper capacity.** A separate branch circuit, sized according to the National Electrical Code for the current shown on the pump name plate is recommended.
4. **TESTING FOR GROUND.** As a safety measure, each electrical outlet should be checked for ground using an Underwriters Laboratory Listed circuit analyzer which will indicate if the power, neutral and ground wires are correctly connected to your outlet. If they are not, call a qualified licensed electrician.
5. **FOR YOUR PROTECTION ALWAYS DISCONNECT PUMP FROM ITS POWER SOURCE BEFORE HANDLING.** If pump is wired direct, **de-energize the circuit at the control box.** Grounded pumps are supplied with a 3-prong grounded plug to help protect you against the possibility of electrical shock. **DO NOT UNDER ANY CIRCUMSTANCES REMOVE THE GROUND PIN.** To reduce the risk of electrical shock, a properly grounded receptacle or control box of grounding type must be installed and protected by a ground fault circuit interrupter (GFCI) in accordance with national electrical code and applicable local codes.
6. Installation and checking of electrical circuits and hardware should only be performed by a qualified licensed electrician.
7. According to the state of California (Prop 65), this product contains chemicals known to the state of California to cause cancer and birth defects or other reproductive harm.

CAUTION

SEE BELOW FOR LIST OF CAUTIONS

1. Check to be sure your power source is adequate to handle the amperage requirements of the motor as indicated on the pump or unit I.D. tag.
2. All plumbing (discharge and vent lines) must be installed to meet local codes. **Unit must be vented. Do not use an automatic plumbing vent device. Toilet will not flush.**
3. Maximum continuous operating temperature for models 100 and 102 must not exceed 130°F (54°C). Maximum continuous operating temperature for model 101 must not exceed 110°F (43°C).

NOTES

SEE BELOW FOR LIST OF NOTES

1. Repair and service should be performed by an Authorized Service Station only. (Consult factory.)
2. NOTE: Recommended for installations up to 13' (Models 100/101) and 16' (Model 102) total dynamic head. Consult factory if installation is above 15' vertical height in 2" pipe. Sewage Pumps WM266, WM264 and WM211 are designed for use in Qwik Jon® units only. They are not designed for use in any other application.
3. Do not use wax seal having flange that extends into tank; it may cause clogging. If a floor is installed over the tank, use a Zoeller designed floor flange extender seal kit (Included).
4. For installation below the original floor line, consult Factory.

NOTE: Pumps with the "UL" mark and pumps with the "US" mark are tested to UL Standard UL778. CSA Certified pumps are certified to CSA Standard C22.2 No.108.

REFER TO WARRANTY ON PAGE 2.

LIMITED WARRANTY

Manufacturer warrants, to the purchaser and subsequent owner during the warranty period, every new product to be free from defects in material and workmanship under normal use and service, when properly used and maintained, for a period of one year from date of purchase by the end user, or 18 months from date of original manufacture of the product, whichever comes first. Parts that fail within the warranty period, one year from date of purchase by the end user, or 18 months from the date of original manufacture of the product, whichever comes first, that inspections determine to be defective in material or workmanship, will be repaired, replaced or remanufactured at Manufacturer's option, provided however, that by so doing we will not be obligated to replace an entire assembly, the entire mechanism or the complete unit. No allowance will be made for shipping charges, damages, labor or other charges that may occur due to product failure, repair or replacement.

This warranty does not apply to and there shall be no warranty for any material or product that has been disassembled without prior approval of Manufacturer, subjected to misuse, misapplication, neglect, alteration, accident or uncontrollable act of nature; that has not been installed, operated or maintained in accordance with Manufacturer's installation instructions; that has been exposed to outside substances including but not limited to the following: sand, gravel, cement, mud, tar, hydrocarbons, hydrocarbon derivatives (oil, gasoline, solvents, etc.), or other abrasive or corrosive substances, wash towels

or feminine sanitary products, etc. in all pumping applications. The warranty set out in the paragraph above is in lieu of all other warranties expressed or implied; and we do not authorize any representative or other person to assume for us any other liability in connection with our products.

Contact Manufacturer at, 3649 Cane Run Road, Louisville, Kentucky 40211, Attention: Customer Support Department to obtain any needed repair or replacement of part(s) or additional information pertaining to our warranty.

MANUFACTURER EXPRESSLY DISCLAIMS LIABILITY FOR SPECIAL, CONSEQUENTIAL OR INCIDENTAL DAMAGES OR BREACH OF EXPRESSED OR IMPLIED WARRANTY; AND ANY IMPLIED WARRANTY OF FITNESS FOR A PARTICULAR PURPOSE AND OF MERCHANTABILITY SHALL BE LIMITED TO THE DURATION OF THE EXPRESSED WARRANTY.

Some states do not allow limitations on the duration of an implied warranty, so the above limitation may not apply to you. Some states do not allow the exclusion or limitation of incidental or consequential damages, so the above limitation or exclusion may not apply to you.

This warranty gives you specific legal rights and you may also have other rights which vary from state to state.

HELPFUL HINTS FOR EASY INSTALL

1. Read all instructions before beginning installation.
2. Be sure the installation has a minimum of 5 feet vertical head.
3. Be sure the floor is level within 1/8" for the length and width of the tank.
4. Install 2" discharge pipe seal with flange side of seal on inside of lid. See Figure 7.2 on page 6. (Models 100 & 102 only)
5. Use soapy water to lubricate all seals to aid installation.
6. Install rubber coupling/union in vent line to aid disassembly. See Figure 7.4 on page 6.
7. Test unit before mounting toilet. Check On/Off levels per step 6 of instructions.
8. Do not over torque toilet mounting screws.
9. Do not use an automatic plumbing vent device.
10. Obtain model number and date code, and record information in the space provided on the front of this manual. Refer to this information when calling factory.

DO'S AND DON'T'S FOR INSTALL

1. DO read all installation material with the pump and tank.
2. DO inspect unit for any visible damage caused by shipping. Contact dealer if unit appears to be damaged.
3. DO clean all visible debris from the tank.
4. DO always disconnect pump from power source before handling. DO always connect to a separately protected and properly grounded ground fault protected circuit. DO NOT ever cut, splice or damage power cord. DO NOT carry or lift pump by its power cord. DO NOT use an extension cord with a sewage pump.
5. DO install a check valve and a union in the discharge line. DO NOT use a discharge pipe smaller than the pump discharge size.
6. DO test pump immediately after installation to be sure that the system is working properly.
7. DO review all applicable local and national codes and verify that the installation conforms to each of them.
8. We DO NOT recommend this product be connected to utilities other than those found in a normal bathroom application. Washing machines and dishwashers are examples of equipment that we Do NOT recommend.

PERFORMANCE CHARACTERISTICS

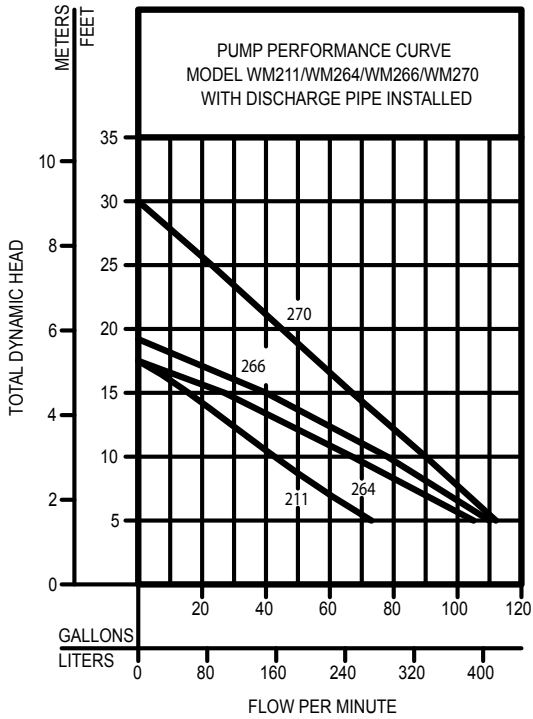

TOTAL DYNAMIC HEAD/FLOW
PER MINUTE
SEWAGE AND DEWATERING

MODEL	WM211 MODEL 101		WM264 MODEL 100		WM266 MODEL 102		WM270 MODEL 103		
	Feet	Meters	Gal.	Liters	Gal.	Liters	Gal.	Liters	
5	1.5	73	276	105	397	110	416	112	424
10	3.0	39	148	67	254	78	295	90	341
15	4.6	19	72	27	102	40	151	67	254
20	6.1	--	--	--	--	--	--	45	170
25	7.6	--	--	--	--	--	--	23	87
Shut-off Head:		17.5 ft.(5.3m)		17.5 ft.(5.3m)		19.2 ft.(5.9m)		30.0 ft.(9.1m)	

009966

DIMENSIONAL DATA

A	B	C	D	E	F	G	H	I	J
12 $\frac{1}{4}$	12 $\frac{1}{4}$	5 $\frac{1}{2}$	13 $\frac{1}{4}$	14 $\frac{1}{8}$	42 $\frac{3}{16}$	24 $\frac{1}{2}$	17	13 $\frac{1}{2}$	20 $\frac{1}{2}$

All dimensions are in inches.

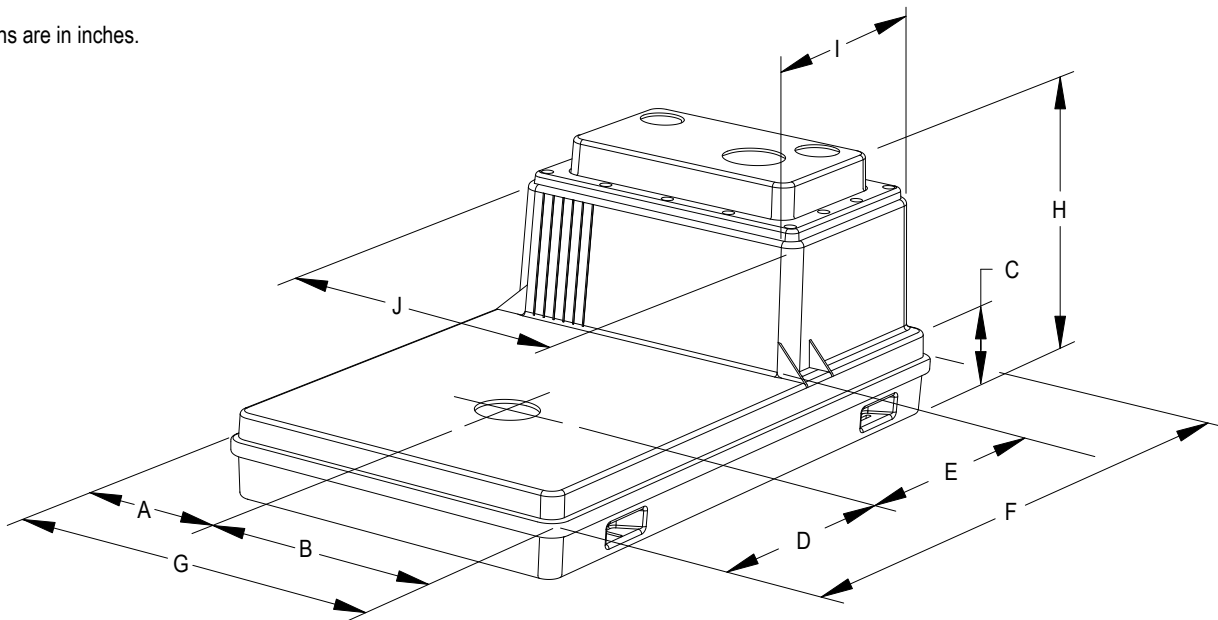

SK1610

STEP 1 LOCATION SELECTION AND LEVELING OF TANK

NOTE: If a built in installation is to be used, locate pump chamber in an area that will allow access to the pump & switch.

- 1.1) Select a location which is readily accessible to the existing discharge and vent lines.
- 1.2) Level tank to within $\frac{1}{8}$ " for length and width. Use hydraulic cement or similar material for leveling. Refer to Figure 1.1.

▲ CAUTION Do not use wooden shims to level tank!

▲ CAUTION Ensure that nails, screws or other sharp objects do not puncture tank!

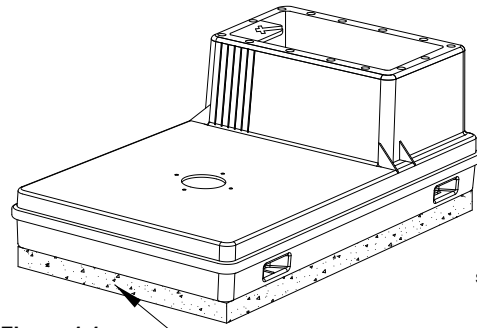

Figure 1.1

LEVEL WITH
HYDRAULIC CEMENT
OR SIMILAR MATERIAL

SK1746

STEP 2 ORIENTATION OF TOILET ON TANK

- 2.1) Determine the orientation of toilet on tank. This determines the location of the long bolts in STEP 3 of the installation. Refer to Figure 2.1 or Figure 2.2.

NOTE: Model 101 comes preassembled in the forward installation position. If a side installation is desired, bolts must first be removed and then reinstalled per STEP 3. Also, if subflooring is being installed, the 2" bolts must be removed and replaced with 3" bolts per STEP 3.

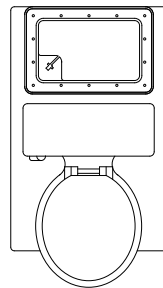

Forward Installation
Figure 2.1

OR

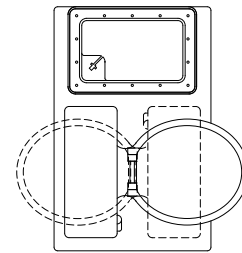

Side Installation
Figure 2.2

SK1747

STEP 3 INSTALLATION OF THE CAST IRON SUPPORT

Model 101: If the bolts are correct for your desired installation, skip to STEP 6.

NOTE: If subflooring is being installed over the tank, use the $\frac{1}{4}$ " - 20 X 3" long bolts supplied with the floor flange extender kit, otherwise use the $\frac{1}{4}$ " - 20 X 2" long bolts. The longer bolts account for the thickness of the subflooring when mounting toilet.

- 3.1) Drill the 4 preselected holes, located around the toilet opening, with a $\frac{9}{32}$ " drill bit. (Models 100 & 102 only)
- 3.2) Modify the 4 foam gaskets, supplied with the wax ring kit, as shown in Detail "A". (Models 100 & 102 only)
- 3.3) Install the cast iron plate inside the tank through the pump chamber with the flat side up. Rotate the plate to rest on tank supports. (Models 100 & 102 only)
- 3.4) Make certain that the 2" or 3" long toilet mounting bolts are in the correct locations to accept the toilet as determined in STEP 2. Torque screws to 25-30 in-lbs.

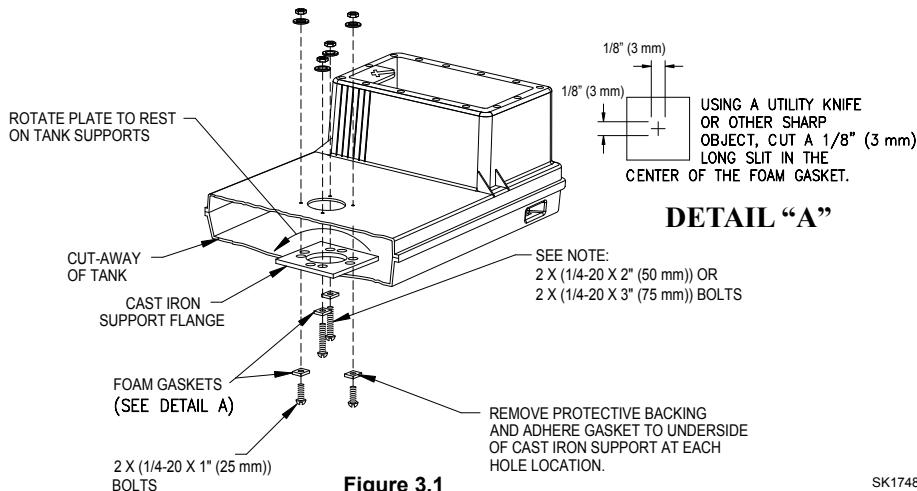

Figure 3.1

SK1748

STEP 4 ASSEMBLY OF THE FLOAT SWITCH (MODELS 100 & 102 ONLY)

- 4.1) Assemble float switch components as shown in Figure 4.1 & 4.2.
- 4.2) Slide float stop down to 1 inch above float.

NOTE: a) Setting float control to come on sooner will increase the delay between when the pump starts and when it begins delivering water.

b) If adjustment is necessary, move the float stops up or down along the float rod. Ensure that the pump turns on at a maximum of 4½”.

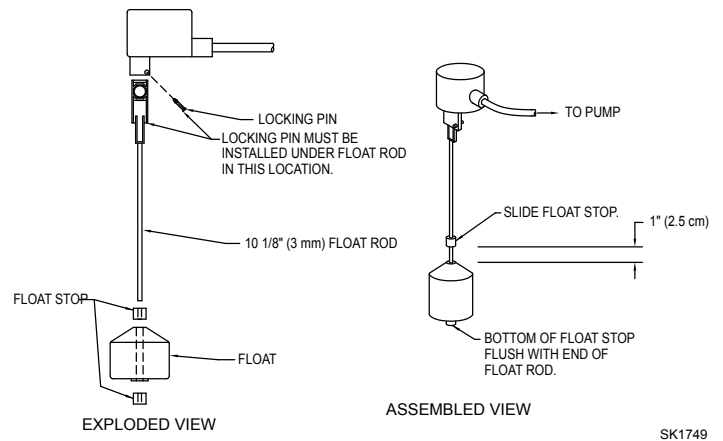

Figure 4.1

Figure 4.2

SK1749

STEP 5 INSTALL OF PUMP & FLOAT SWITCH INTO TANK (100 & 102 ONLY)

- 5.1) Install the discharge pipe onto the pump as shown in Figure 5.1.
- 5.2) Place the pump into the tank as shown in Figure 5.2.
- 5.3) Mount the float switch as shown on Detail “A”.

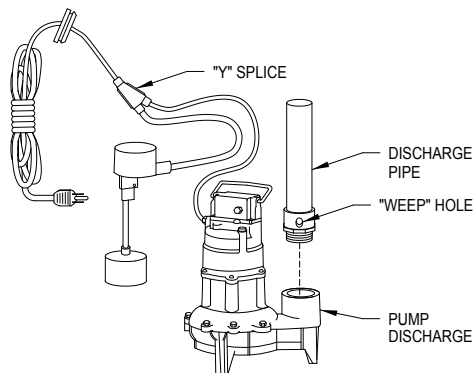

Model 100 Pump Shown
Figure 5.1

SK1750

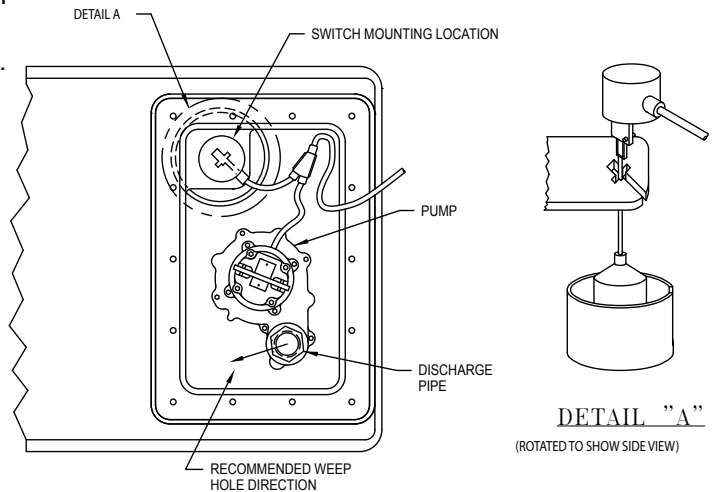

Figure 5.2

SK1751

Note: Float switch will be “loose” until lid is installed.
Note: Model 102 does not have a “Y” splice.

STEP 6 TESTING OF PUMP OPERATION

NOTE: Measure water level at float switch on Models 100 & 102 for best accuracy. Model 101 has been preset but should also be checked per instructions below.

- 6.1) With the lid removed, temporarily connect the pump discharge pipe to the house drain pipe. **Model 101 can be checked through the toilet inlet to avoid removal of the preassembled lid.**
- 6.2) Plug in pump.
- 6.3) Fill the tank with 4” of water as shown in Figure 6.1. The pump should not turn “ON”!
- 6.4) Fill the tank with an additional ½” of water. The pump should turn “ON” before the water level reaches 4½”. Refer to the Troubleshooting Guide, on page 11, for problem diagnosis.
- 6.5) Unplug pump and disconnect discharge piping and continue to STEP 7.

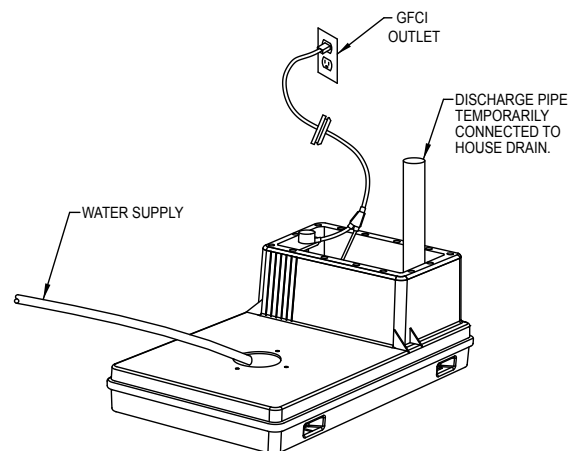

Figure 6.1

SK1752

STEP 7 INSTALLATION OF LID AND ASSOCIATED PLUMBING

NOTE: STEPS 7.1 - 7.3 are for Models 100 & 102 only. For Model 101, skip to 7.4.

- 7.1) Apply foam gasket material to flange of pump chamber, leaving an overlap of gasket material as shown in Figure 7.1.
- 7.2) Install the Lid components as shown in Figure 7.2.
- 7.3) Install the Lid onto the pump chamber as shown in Figure 7.3.
- 7.4) Complete installation as shown in Figure 7.4.

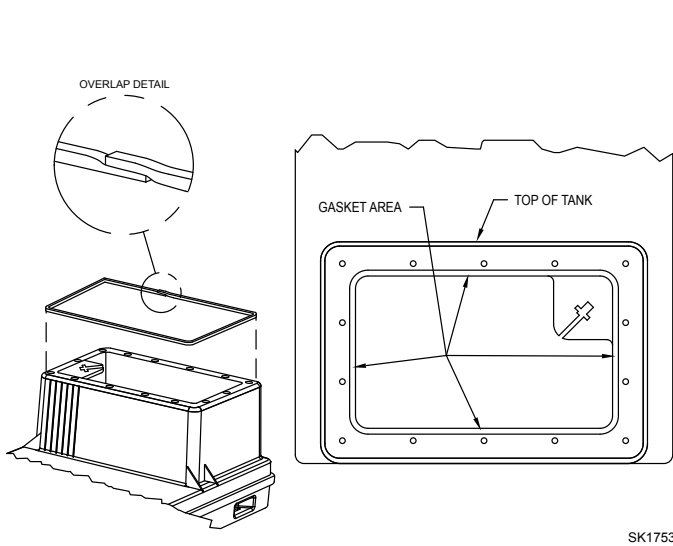
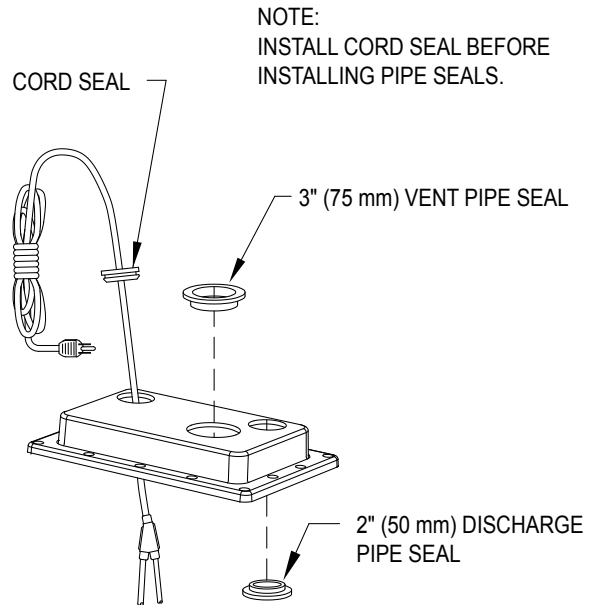

Figure 7.1

SK1753



**NOTE:
INSTALL CORD SEAL BEFORE
INSTALLING PIPE SEALS.**

Figure 7.2

SK1754

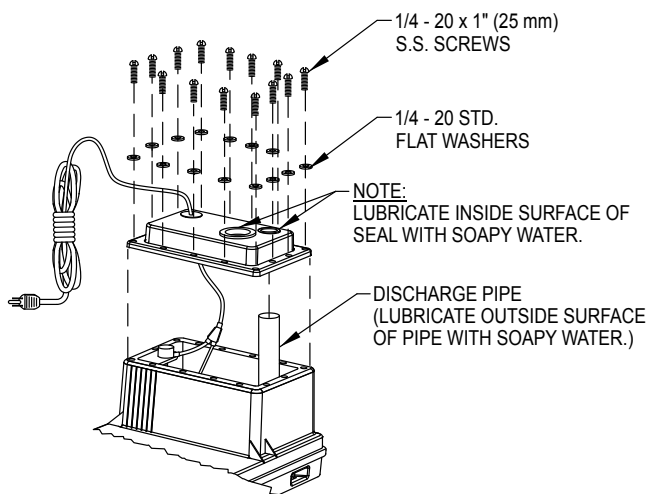

Figure 7.3

SK1755

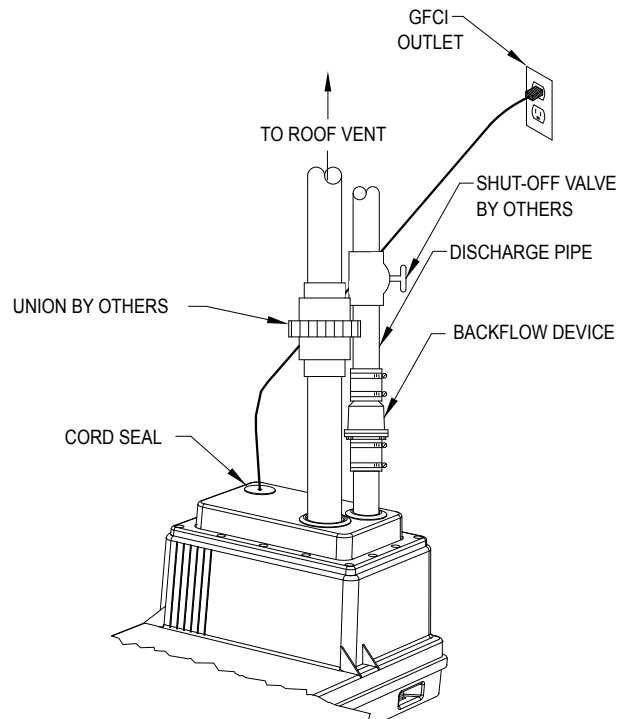

Figure 7.4

SK1756

STEP 8 INSTALLATION OF TOILET

NOTE: Only use the Wax Seal provided with the Floor Flange Extender Kit.

- 8.1) Free standing Installation (No subflooring)
 - 1) Only 1 wax toilet bowl gasket required.
 - 2) Install wax toilet bowl gasket, and toilet as described on the back of the gasket carton.
 - 3) Hook up water line to toilet, fill tank, and test unit.

- 8.2) Installation of Toilet with $\frac{1}{2}$ " or $\frac{3}{4}$ " (Use Floor Flange Extender Kit) Subflooring
 - 1) Both wax toilet bowl gaskets are required.
 - 2) Cut a $6\frac{1}{2}$ " diameter hole in the subfloor centered on the tank opening.
 - 3) Firmly press one of the wax toilet bowl gaskets into the plastic locator ring.
 - 4) Place plastic locator ring on tank and firmly press into place until wax has completely filled the ring. This can be checked through the 4 air holes on the locator ring.
 - 5) To complete installation, refer to the back of the toilet gasket carton for directions.
 - 6) Hook up water line to toilet, fill tank, and test unit.

STEP 9 INSTALLATION OF ADDITIONAL FIXTURES

- 9.1) In order to add fixtures, a 3" diameter hole must be drilled into the side of the pump chamber using the spotting template located on page 11.
- 9.2) Figure 9.1 shows the location on the pump chamber which can be used for adding additional fixtures.
CAUTION Do not plumb into the vertical ribs located on the front left corner of the pump chamber.
- 9.3) Affix the spotting template on the desired location and center the punch hole center. Use a 3" diameter hole saw to drill through pump chamber. **NOTE: Model 101 is preassembled. Use caution when drilling into tank. Be sure to remove drilled plastic material from tank.**
- 9.4) Insert a 2" rubber pipe seal (included) into the 3" hole and lubricate the inside diameter with soapy water to allow for ease of pipe insertion.
- 9.5) Insert pipe through seal approximately $\frac{3}{4}$ " into tank.
- 9.6) Refer to Figures 9.2 - 9.5 for Typical installation of Tubs & Lavatories.

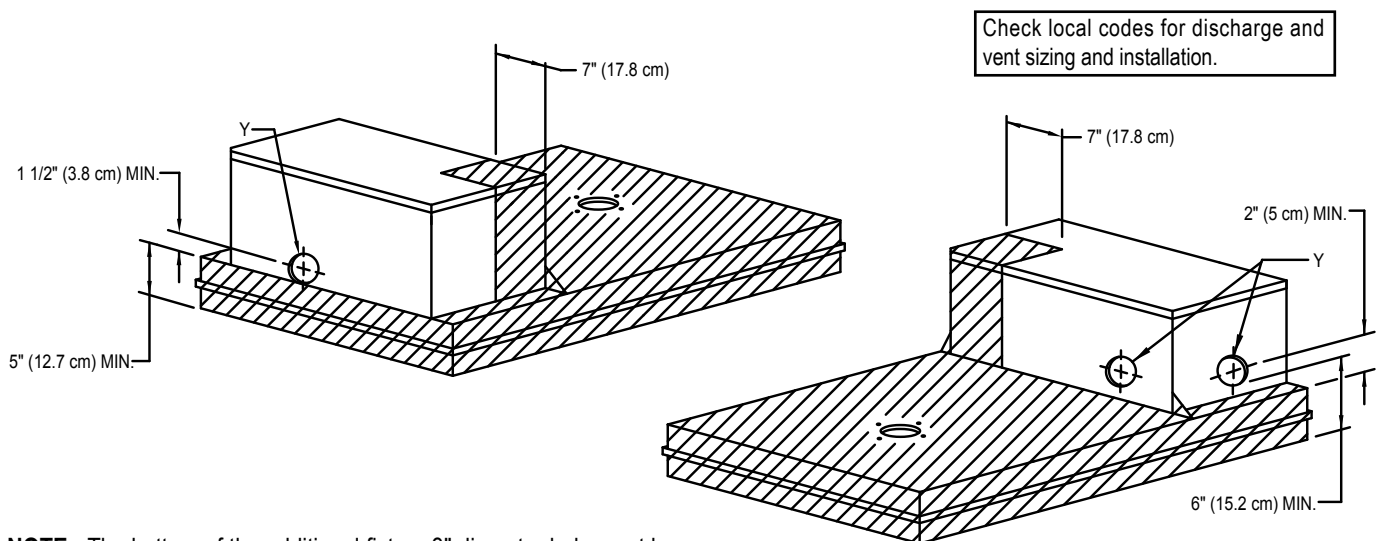

NOTE: The bottom of the additional fixture 3" diameter hole must be 5" or 6" minimum above the base of the tank depending upon which side of the tank is selected. Refer to drawing above. Cut out spotting template on page 11. **Do not plumb into "crosshatched" area.**

Figure 9.1

STEP 9

INSTALLATION OF ADDITIONAL FIXTURES, *continued*

TYPICAL INSTALLATION WITH RAISED TUB, LAVATORY, VENT & DISCHARGE

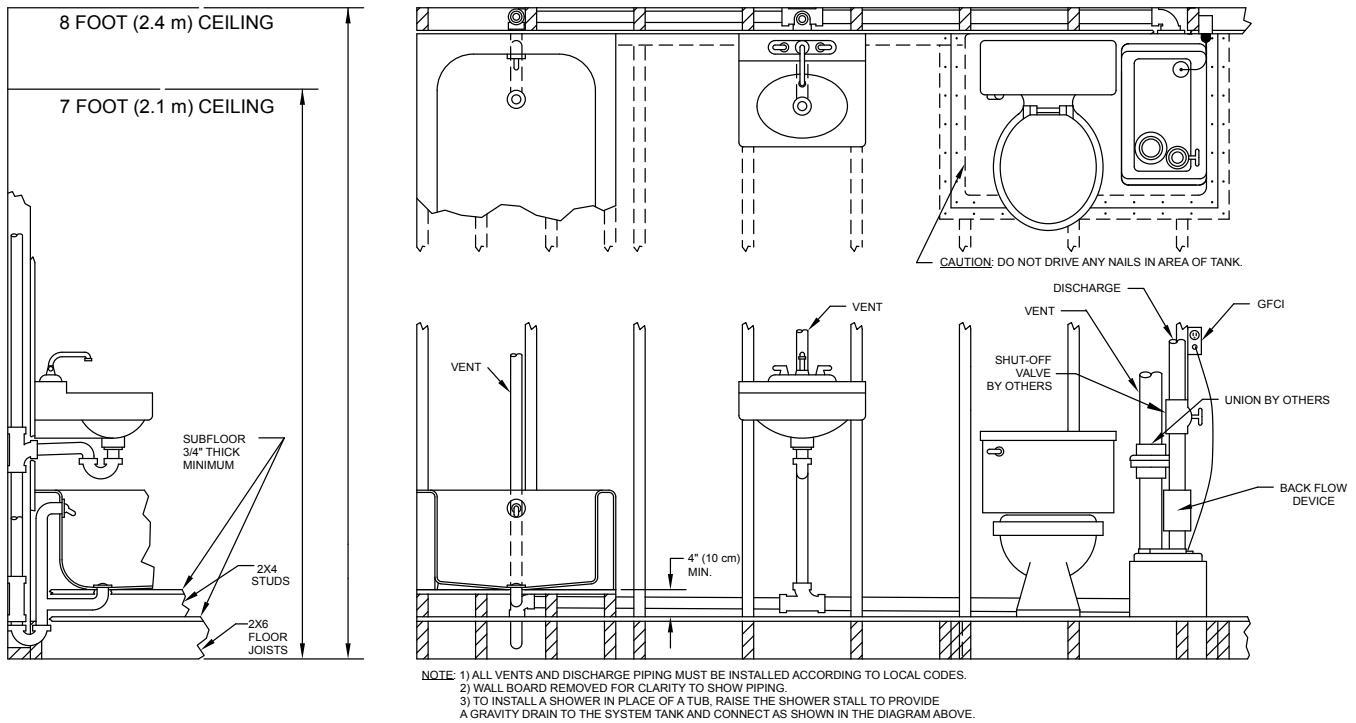

Figure 9.2

SK1615

ALTERNATE INSTALLATION WITH SPECIAL FLOOR MOUNTED RAISED BOTTOM TUB, LAVATORY, VENT & DISCHARGE

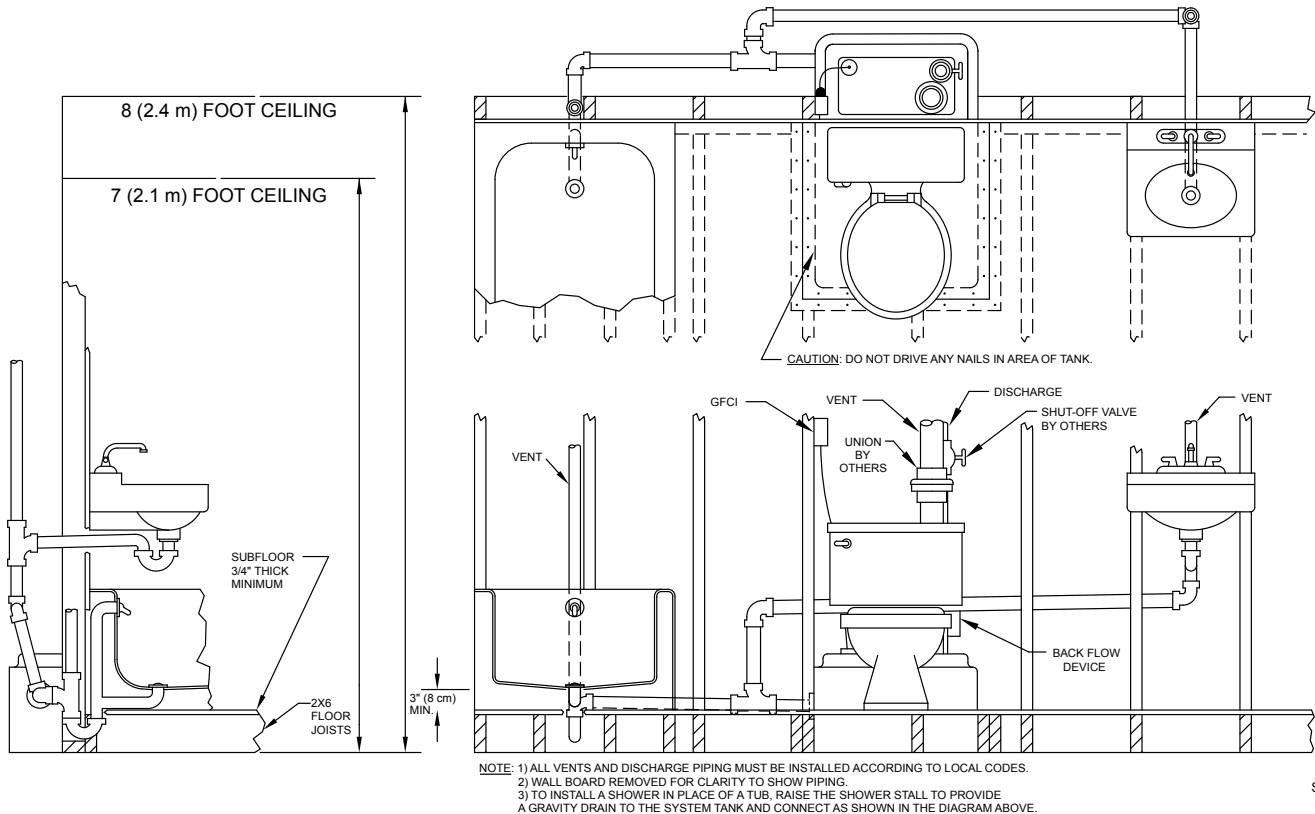

Figure 9.3

SK1616

ALTERNATE INSTALLATION WITH RAISED TUB, LAVATORY, VENT & DISCHARGE

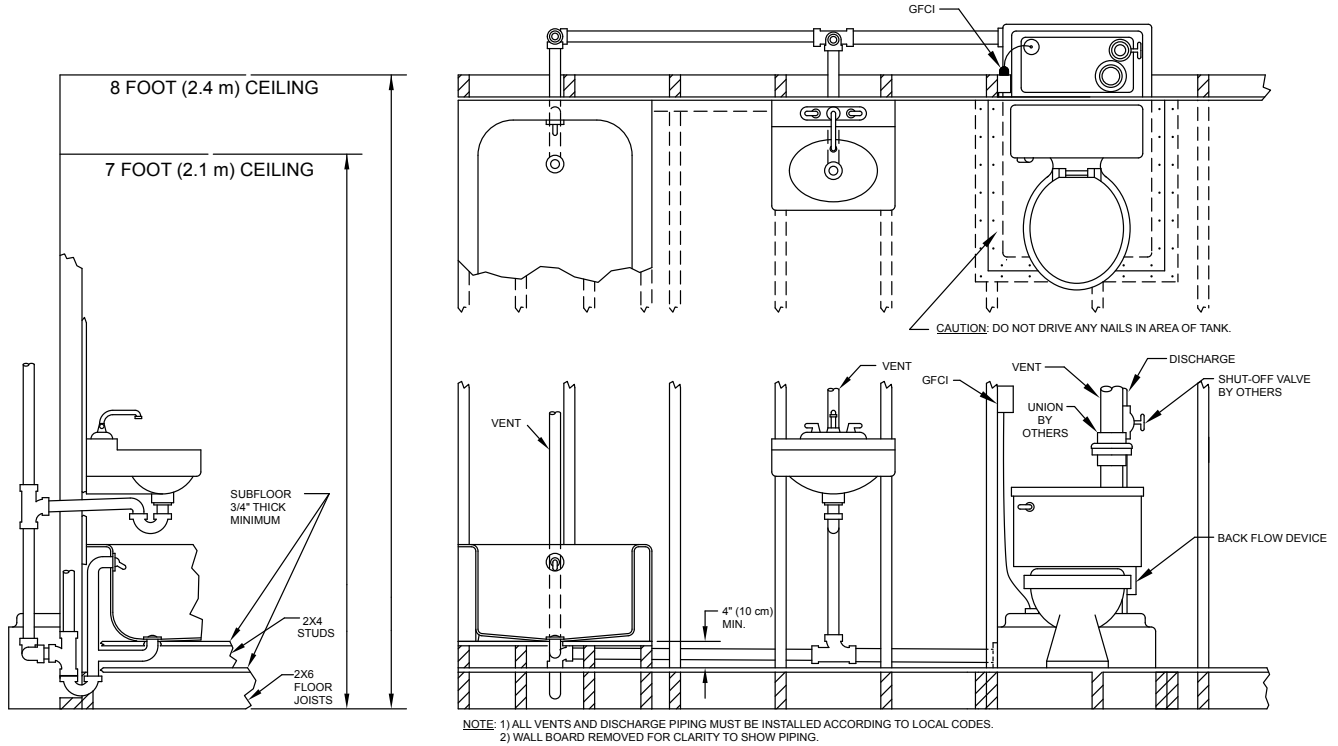

Figure 9.4

SK1617

ALTERNATE INSTALLATION WITH SPECIAL FLOOR MOUNTED RAISED BOTTOM TUB, LAVATORY, VENT & DISCHARGE

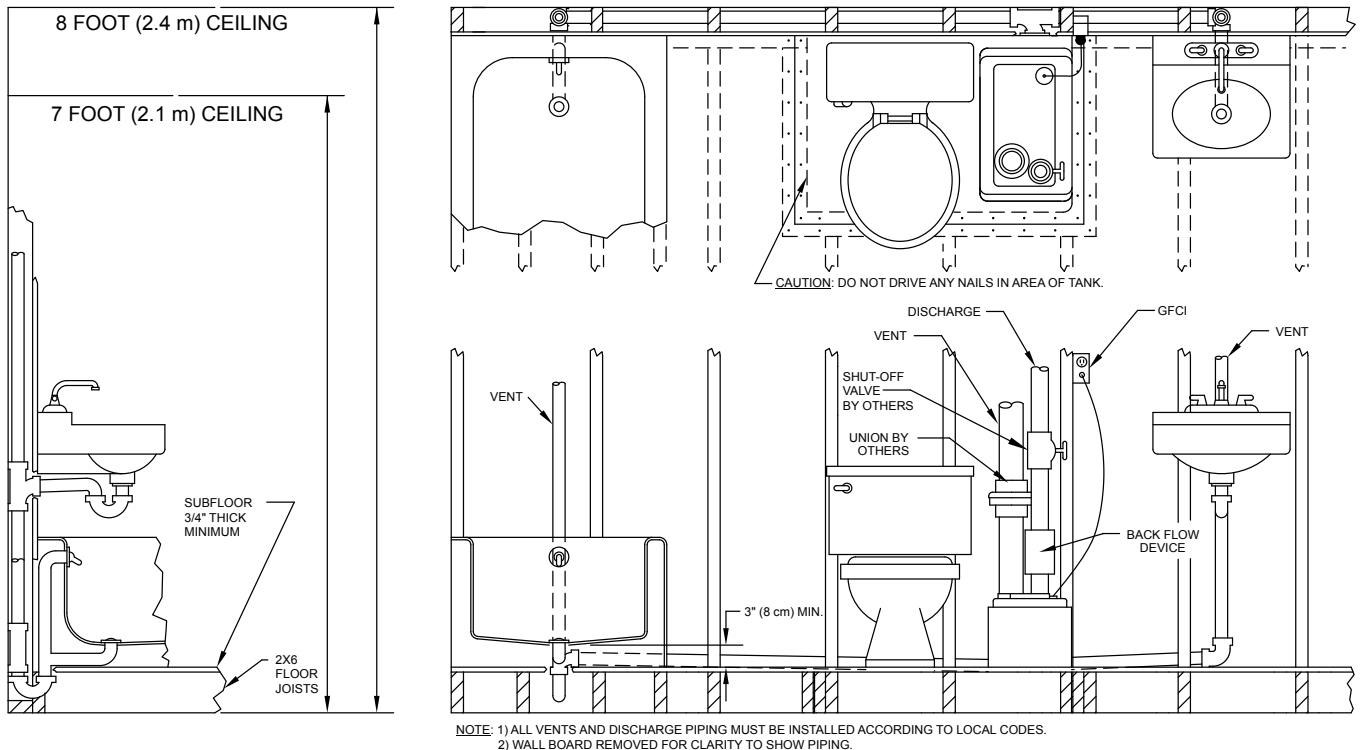
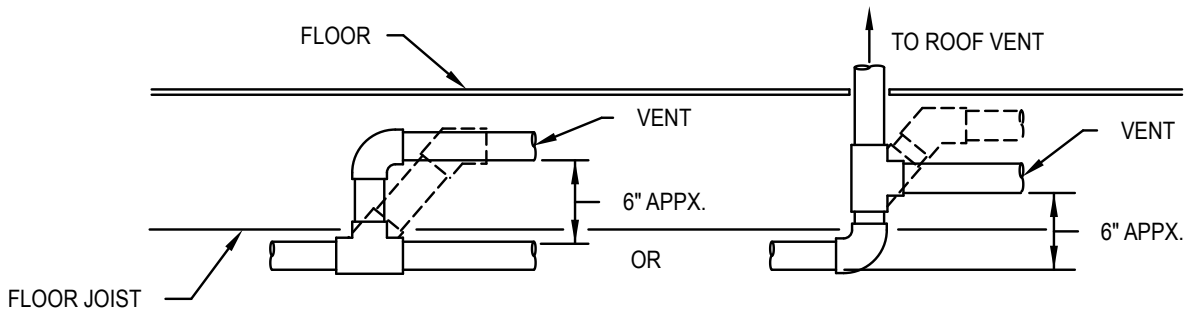

Figure 9.5

SK1618

TYPICAL PIPING CONFIGURATIONS



NOTE: ALL VENTS AND DISCHARGE PIPING MUST BE INSTALLED ACCORDING TO LOCAL CODES. 5' VERTICAL ELEVATION REQUIRED ON DISCHARGE PIPE.

3" (4") x2" Y OR TEE CAST IRON W/NO HUB CONNECTORS

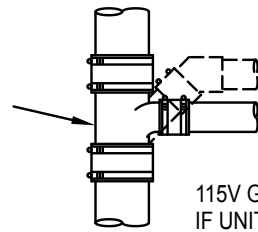

115V GROUND FAULT CIRCUIT INTERRUPTER (GFCI). IF UNIT IS 230V THEN INSTALL GFCI PROTECTION IN THE ELECTRICAL PANEL.

3" (4") x2" Y OR TEE WELDED IN PLASTIC.

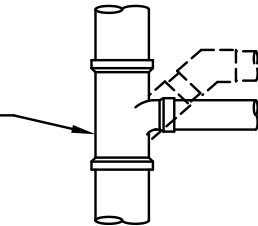

DISCHARGE TO 3" OR LARGER SEWAGE DRAIN LINE. USE SANITARY TEE OR Y WITH NO HUB CONNECTOR OR WELD IN A TEE OR Y IN PLASTIC PIPE.

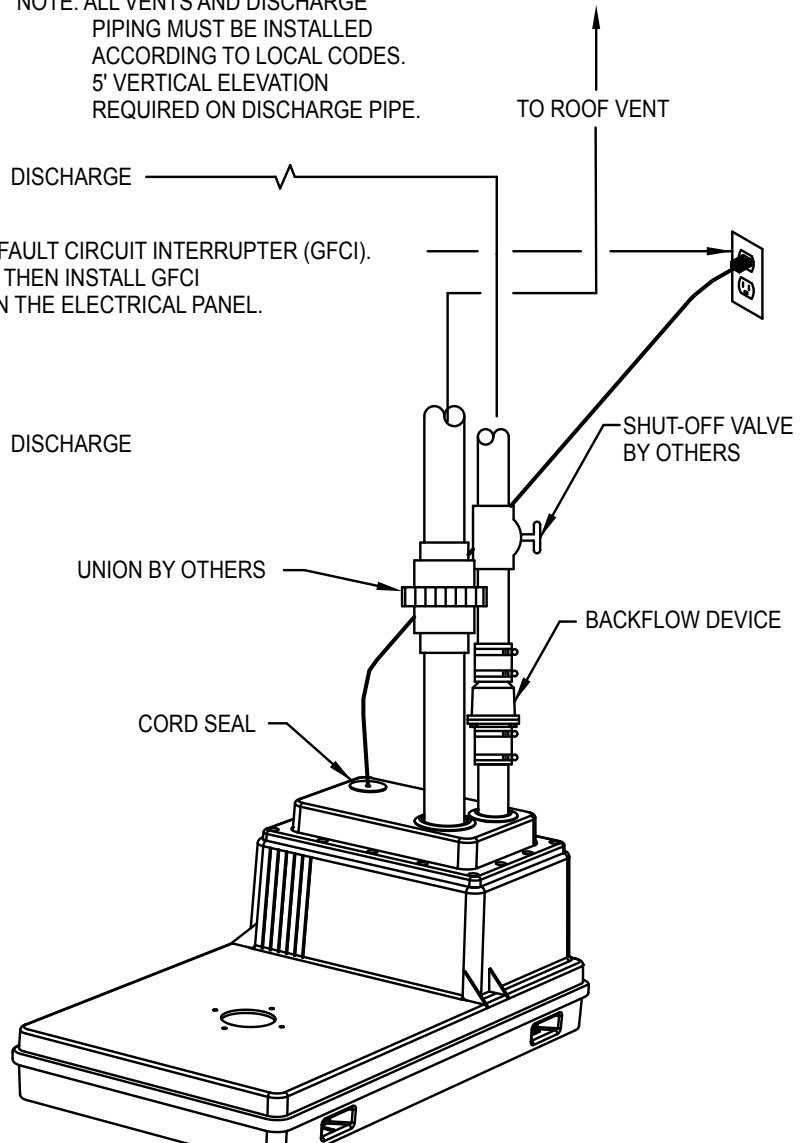

NOTE: All installations must comply with all applicable Electrical and Plumbing Codes, including, but not limited, to National Electrical Code: Local: Regional and/or State Plumbing Codes, etc.

SK1586

REPLACEMENT PARTS LIST FOR MODELS 100, 101, 102 & 103

MODELS:		100-D	101-A	102-E	103-A	
REF. NO.	DESCRIPTION	QTY	WM264 (10/97 to Present)	WM211 (07/01 to Present)	WM266 (10/97 to Present) WD266 (11/99 TO Current)	WM270 (10/95 to Current) WD270 (06/00 to Current)
1	Tank & Lid Assembly	1	010658	010658	010658	010658
2	Tank	1	011022	011022	011022	011022
3	Lid	1	011023	011023	011023	011023
4	Hardware Pack	1	010497	010497	010497	010497
5	Toilet Flange	1	005521	005521	005521	005521
6	Pump - WM264 (115V)	1	014955	NA	NA	NA
	Pump - WM211 (115V)		NA	014821	NA	NA
	Pump - WM266 (115V)		NA	NA	014955	NA
	Pump - WD266 (230V)		NA	NA	010514	NA
	Pump - WM270 (115V)		NA	NA	NA	011853
	Pump - WD270 (230V)		NA	NA	NA	152118
7	Back Flow Device	1	006817	006817	006817	006817
15	Discharge Pipe	1	008515	008515	008515	008515
16	Switch Hardware Pack	1	010532	010532	010532	010532
21	Kit, Wax Ring Seal	1	008634	008634	008634	008634

HARDWARE PACK P/N 010497 (MODELS 100-D, 101-A, 102-E & 103-A)			
ITEM	P/N	DESCRIPTION	QTY
8	005588	Seal, Discharge 2"	2
9	005587	Seal, Vent 3"	1
10	004529	Screw, .25-20 X 2"	2
11	004480	Washer, SS-.25" Standard Flat	20
12	001812	Nut, .25-20 H-SS	6
13	004531	Screw, .25-20 X 1" LG RHM SS	16
14	010524	Seal, Foam - Closed Cell	1
SWITCH HARDWARE PACK P/N 010532			
17	009121	Float Rod Pin	1
18	010499	Float Rod	1
19	009120	Float Rod Stops	2
20	009119	Float Bulb	1

Note: Components are shipped each.

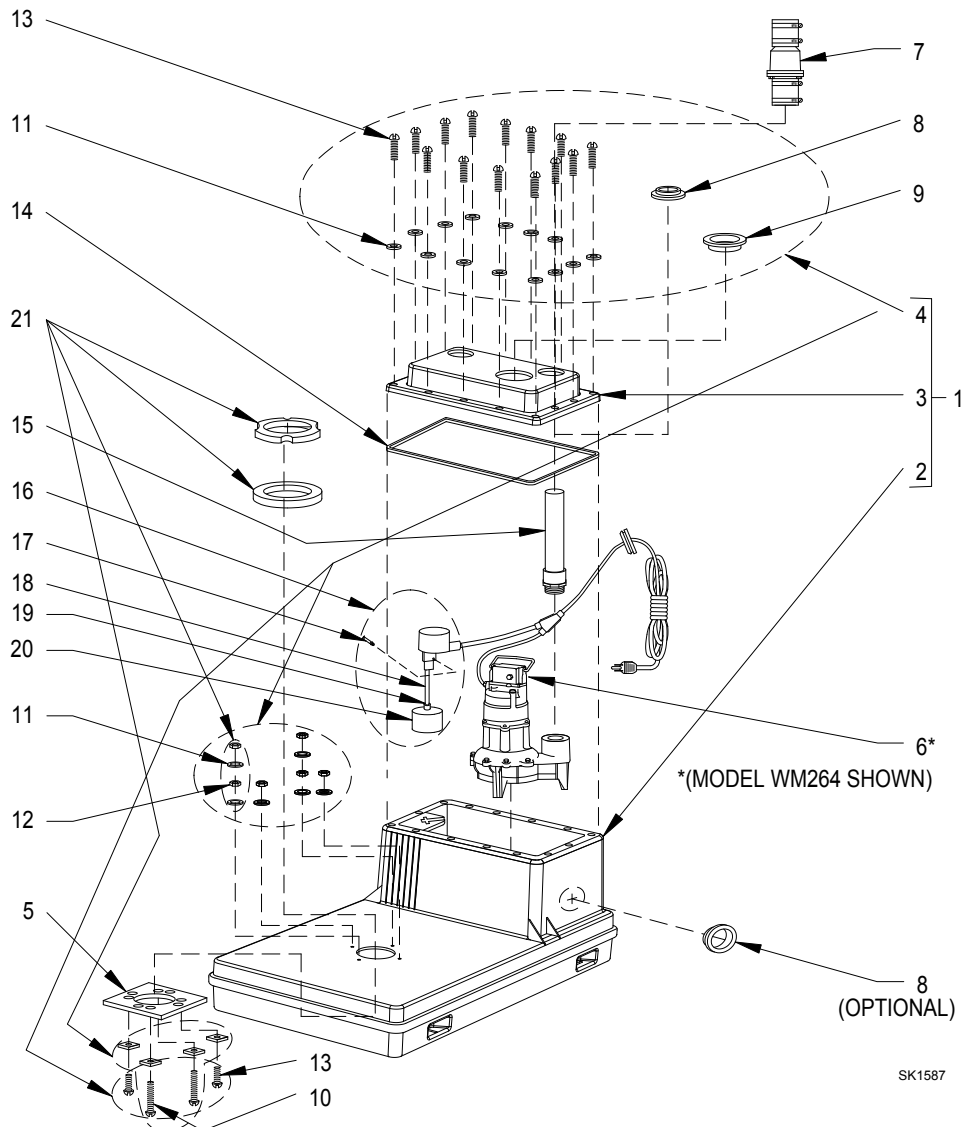

SK1587

TROUBLE SHOOTING

CONDITION	POSSIBLE CAUSE	REMEDY
A. PUMP WILL NOT START OR RUN.	Low voltage, blown fuse, open circuit.	Have a qualified electrician check fuse and circuit.
	Impeller bound.	Contact a Zoeller Service Station.
	Motor or wiring shorted.	
	Debris on float switch.	Remove debris
B. PUMP STARTS TOO SOON.	Float "ON" point is adjusted too low.	Raise the float stops, make sure the float is between the two stops.
C. WATER LEVEL EXCESSIVE BEFORE PUMP TURNS ON.	Float "ON" point adjusted to high.	Lower the upper float stop.
D. PUMP WILL NOT SHUT OFF OR RUNS TOO LONG BEFORE WATER IS PUMPED.	Debris under float.	Remove debris from around float.
	Faulty float switch.	Contact a Zoeller Service Station.
	Float "Off" point adjusted too low.	Raise the lower float stop.
	Pump is air locked.	Make sure vent hole in discharge pipe is clear.
	Water level too low.	Raise the lower float stop.
	Waste material has accumulated blocking flow of material.	Hold flush handle down on toilet for 15 seconds. If unit will not clear, unplug and wait 30 minutes. Plug unit back in and repeat. If unit still will not turn off, it will need to be opened and the debris relocated.
E. PUMP OPERATES, BUT DELIVERS LITTLE OR NO WATER.	Debris around intake.	Clean area around intake.
	Blockage in discharge pipe.	Remove pipe and flush out debris.
	Low or incorrect voltage.	Have a qualified electrician check house wiring.
	Damaged Impeller.	Contact a Zoeller Service Station.
	Incorrect float adjustment.	Contact Product Support Department.
	Pump is air locked.	Make sure vent hole in discharge pipe is clear.
	Vertical lift too high.	Change discharge piping or contact Product Support Department.

If the above checklist does not solve the problem, consult the Zoeller Product Support Department (502) 778-2731. **Do not** attempt to service or otherwise disassemble pump. Care of finish: Soap and water is all that is recommended for cleaning the outside of the tank. Other cleaning products may cause discoloration and scratching.

SPOTTING TEMPLATE

Pipe installed in this 2" seal must be supported vertically.
 Hole must be round. Use 3" hole saw.
 Hole sizes greater than 3.040" can create leaks.

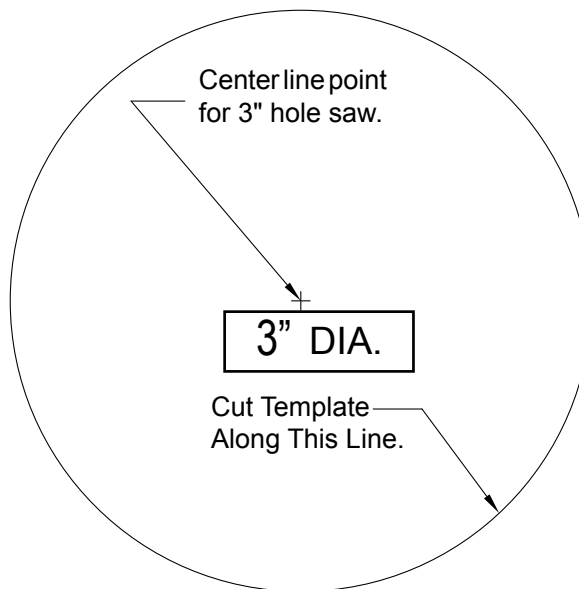

SK1279



PUMP COMPANY

MAIL TO: P.O. BOX 16347 • Louisville, KY 40256-0347
 SHIP TO: 3649 Cane Run Road • Louisville, KY 40211-1961
 (502) 778-2731 • 1 (800) 928-PUMP • FAX (502) 774-3624

Your Peace of Mind is Our Top Priority®

visit our web site:
www.zoeller.com