

Product information presented here reflects conditions at time of publication. Consult factory regarding discrepancies or inconsistencies.

Patent No. 8,535,014  
Automatic model only

# TECHNICAL DATA SHEET

## HIGH HEAD FLOW-MATE SERIES

Models X161, X163, X165 Effluent Pumps For Hazardous Location  
Class I, Division 1, Groups C & D Rated  
Class I, Zone 1, Groups IIA & IIB

### PRODUCT SPECIFICATIONS

<b>MOTOR</b>	Horse Power	1/2 (X161, X163) or 1 (X165)
	Voltage	115 - 575
	Phase	1 or 3 Ph
	Hertz	60 Hz
	RPM	3450
	Type	Permanent split capacitor or 3 Ph
	Insulation	Class B
	Amps	2.4 - 15.5
<b>PUMP</b>	Operation	Automatic or nonautomatic
	Auto On/Off Points	19-1/2" (495 mm) / 9-3/4" (248 mm)
	Discharge Size	1-1/2" NPT (optional 2" or 3" flange)
	Solids Handling	3/4" (19 mm) spherical solids
	Cord Length	20' (6 m) standard
	Cord Type	UL listed 5-wire (1 Ph) or 8-wire (3 Ph) SOOW
	Max. Head	86.5' (26 m)
	Max. Flow Rate	100 GPM (379 LPM)
	Max. Operating Temp.	104° F (40° C)
	Cooling	Oil filled
	Motor Protection	Auto reset thermal overload (1 Ph) or thermal sensor (3 Ph)
	<b>MATERIALS</b>	Upper Bearing
Lower Bearing		Ball bearing
Mechanical Seals		Carbon and ceramic with stainless steel parts
Impeller Type		Non-clogging vortex
Impeller		Bronze
Hardware		Stainless steel
Gasket		Neoprene square rings

### AUTOMATIC

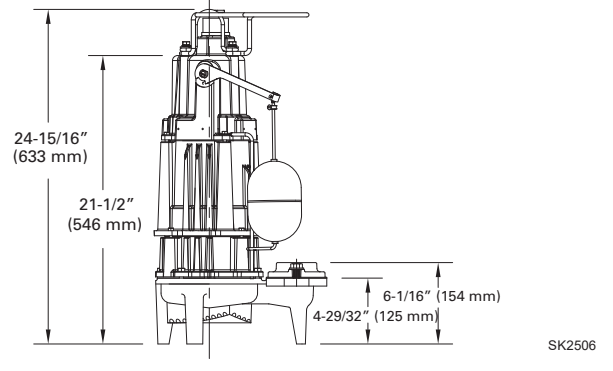
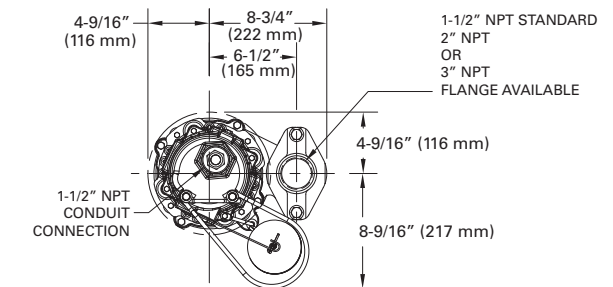

### NONAUTOMATIC

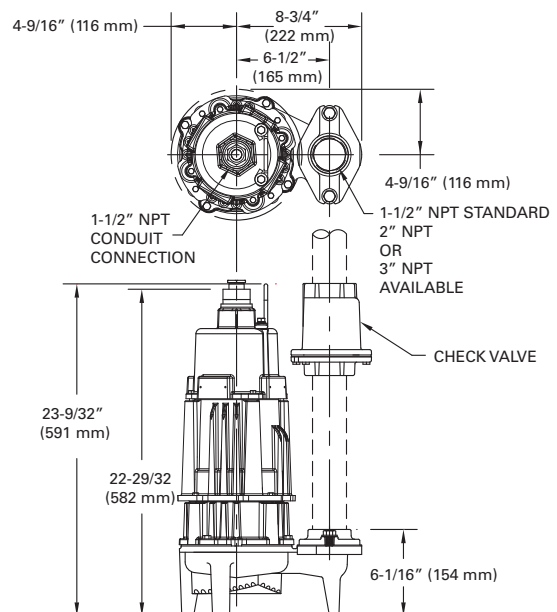

All Class 30 cast iron construction.

NOTE: The sizing of effluent systems normally requires variable level float(s) controls and properly sized basins to achieve required pumping cycles or dosing timers with nonautomatic pumps.

NOTE: See model comparison chart for specific details.

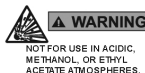

# TOTAL DYNAMIC HEAD FLOW PER MINUTE

MODELS		X161		X163		X165	
Feet	Meters	Gal.	Liters	Gal.	Liters	Gal.	Liters
5	1.5	100	379	61	231	61	231
10	3.0	93	352	60	227	60.5	229
15	4.6	86	326	60	227	60.3	228
20	6.1	79	299	59	223	60	227
25	7.6	71	267	57	216	59	223
30	9.1	62	235	55	208	58	220
40	12.2	45	170	46	174	55	208
50	15.2	20	76	33	125	50	189
60	18.3	--	--	15	57	39	148
70	21.3	--	--	--	--	22.5	85
80	24.4	--	--	--	--	10	38
Shut-off Head:		56 ft. (17.1m)		66 ft. (20.1m)		86.5 ft. (26.4m)	

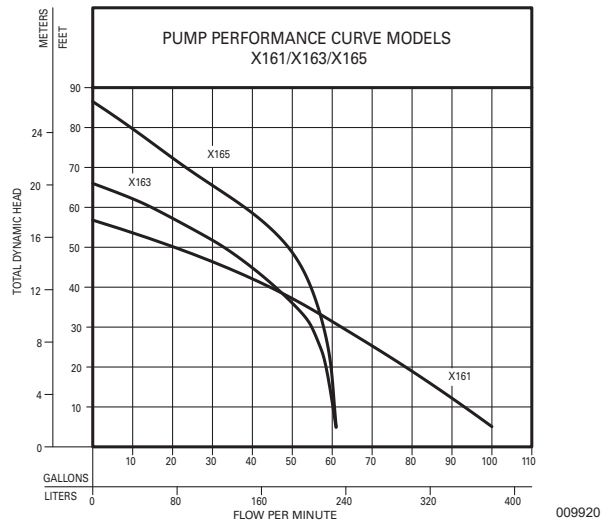

Model	MODEL COMPARISON										
	Seal	Mode	Volts	Ph	Amps	HP	Hz	Lbs	Kg	Simplex	Duplex
MX161	Single	Auto	115	1	15.5	1/2	60	123	55	3 & 4	---
NX161	Single	Non	115	1	15.5	1/2	60	114	51	1 & 2	1 & 2
DX161	Single	Auto	230	1	7.5	1/2	60	123	55	3 & 4	---
EX161	Single	Non	230	1	7.5	1/2	60	114	51	1 & 2	1 & 2
HX161	Single	Auto	200	1	8.8	1/2	60	123	55	3 & 4	---
IX161	Single	Non	200	1	8.8	1/2	60	117	53	1 & 2	1 & 2
JX161	Single	Non	200	3	6.4	1/2	60	117	53	1 & 2	1 & 2
FX161	Single	Non	230	3	5.2	1/2	60	117	53	1 & 2	1 & 2
GX161	Single	Non	460	3	2.9	1/2	60	117	53	1 & 2	1 & 2
BAX161	Single	Non	575	3	2.4	1/2	60	117	53	1 & 2	1 & 2
MX163	Single	Auto	115	1	15.0	1/2	60	123	55	3 & 4	---
NX163	Single	Non	115	1	15.0	1/2	60	114	55	1 & 2	1 & 2
DX163	Single	Auto	230	1	7.5	1/2	60	123	55	3 & 4	---
EX163	Single	Non	230	1	7.5	1/2	60	117	53	1 & 2	1 & 2
HX163	Single	Auto	200	1	8.5	1/2	60	123	55	3 & 4	---
IX163	Single	Non	200	1	8.5	1/2	60	117	53	1 & 2	1 & 2
JX163	Single	Non	200	3	6.0	1/2	60	117	53	1 & 2	1 & 2
FX163	Single	Non	230	3	4.8	1/2	60	117	53	1 & 2	1 & 2
GX163	Single	Non	460	3	2.9	1/2	60	117	53	1 & 2	1 & 2
BAX163	Single	Non	575	3	2.4	1/2	60	117	53	1 & 2	1 & 2
DX165	Single	Auto	230	1	10.2	1	60	124	56	3 & 4	---
EX165	Single	Non	230	1	10.2	1	60	114	51	1 & 2	1 & 2
HX165	Single	Auto	200	1	12.6	1	60	124	56	3 & 4	---
IX165	Single	Non	200	1	12.6	1	60	117	53	1 & 2	1 & 2
JX165	Single	Non	200	3	7.5	1	60	117	53	1 & 2	1 & 2
FX165	Single	Non	230	3	7.4	1	60	117	53	1 & 2	1 & 2
GX165	Single	Non	460	3	3.7	1	60	117	53	1 & 2	1 & 2
BAX165	Single	Non	575	3	3.0	1	60	117	53	1 & 2	1 & 2

Additional cords lengths are available in 25' (8 m), 35' (11 m), and 50' (15 m).

All models are cCSAus approved

Tested to FM Standards 3600 & 3615 by CSA

## SELECTION GUIDE

1. See FM1705 for correct intrinsically-safe simplex or duplex panel
2. See FM0526 for variable level control switches rated 30VDC are used as a control activator. Quantity required dependent upon panel selection.
3. Integral float-operated mechanical switch; no external control required
4. Automatic pumps: Use the optional seal-failure panel (10-1031) to enable the moisture sensor circuit if required by local codes

**CAUTION** All installation of controls, protection devices and wiring should be done by a qualified licensed electrician. All electrical and safety codes should be followed including the most recent National Electrical Code (NEC) and the Occupational Safety and Health Act (OSHA).

© Copyright 2019 Zoeller® Co. All rights reserved.

502-778-2731 | 800-928-7867 | 3649 Cane Run Road | Louisville, KY 40211-1961 | zoellerpumps.com