

Notice to Installer: Instructions must remain with installation.

Your Peace of Mind is Our Top Priority®

SECTION: 6.10.048

FM2100

0414

Supersedes

0805

Product information presented here reflects conditions at time of publication. Consult factory regarding discrepancies or inconsistencies.



PUMP COMPANY

Zoeller Family of Water Solutions™

MAIL TO: P.O. BOX 16347 • Louisville, KY 40256-0347
SHIP TO: 3649 Cane Run Road • Louisville, KY 40211-1961
(502) 778-2731 • 1 (800) 928-PUMP • FAX (502) 774-3624

visit our web site: www.zoeller.com

INSTALLATION INSTRUCTIONS
300 Series End Suction Pumps

PREINSTALLATION CHECKLIST - ALL INSTALLATIONS

- 1. Inspect all materials. Occasionally, products are damaged during shipment. If the unit is damaged, contact your dealer before using.
2. Carefully read all the literature provided to familiarize yourself with specific details regarding installation and use before attempting the installation. These materials should be retained for future reference.

WARNING

SEE BELOW FOR LIST OF WARNINGS

- 1. To help reduce the risk of electrical shock, a proper ground or control box of grounding type must be installed and protected by a ground fault circuit interrupter (GFCI) in accordance with the National Electrical Code and applicable local codes.
2. DO NOT USE AN EXTENSION CORD. Extension cords that are too long or too light do not deliver sufficient voltage to the pump motor. But more important, they could present a safety hazard if the insulation were to become damaged or the connection end were to fall into a damp or wet area.
3. Make sure the pump's electrical supply circuit is equipped with fuses or circuit breakers of proper capacity. A separate branch circuit, sized according to the National Electrical Code for the current shown on the pump name plate is recommended.
4. TESTING FOR GROUND. As a safety measure, electrical supply should be checked for ground using an Underwriters Laboratory Listed circuit analyzer which will indicate if the power, neutral and ground wires are correctly connected. If they are not, call a qualified licensed electrician.
5. Installation and checking of electrical circuits and hardware should only be performed by a qualified licensed electrician.
6. FOR YOUR PROTECTION ALWAYS DISCONNECT PUMP FROM ITS POWER SOURCE BEFORE HANDLING. De-energize the circuit at the control box. If the power point is out-of-sight, lock it in the open position and tag it to prevent unexpected application of power. Failure to do so could result in fatal electrical shock.
7. Unit must be securely and adequately electrically grounded. This can be accomplished by wiring the unit to a ground metal-clad raceway system or by using a separate ground wire connected to the bare metal of the motor frame or other suitable means.
8. Do not put a valve in the discharge line without automatic shut-off capability. Failure to install an automatic shut-off (pressure switch and tank) can allow the pump to run at no flow causing the pumped liquid to overheat and cause steam burns.
9. Risk of electric shock. This pump has not been investigated for use in swimming pool areas.
10. According to the state of California (Prop 65), this product contains chemicals known to the state of California to cause cancer and birth defects or other reproductive harm.
NOTE: Repair and service should be performed by an Authorized Service Station only (Consult factory).
NOTE: Pumps are designed to have a maximum static lift (suction head) of 25 feet (vertical distance from water surface to center line of pump) see suction limitations.
NOTE: Pumps with the CSA CUS mark are tested to UL standard UL 778 and certified to CSA standard C22.2 No. 108.

CAUTION

SEE BELOW FOR LIST OF CAUTIONS

- 1. Check to be sure your power source is adequate to handle the amperage requirements of the motor as indicated on the pump or unit I.D. tag.
2. All plumbing (discharge and intake lines) must be installed to meet local codes.
3. Be certain the pump is completely primed before starting. Otherwise damage may occur to the seal.
4. Be careful when touching the exterior of an operating motor - it may be hot enough to be painful or cause injury.

020294

LIMITED WARRANTY

Zoeller Pump Company warrants, to the purchaser and subsequent owner during the warranty period, every new Zoeller Pump Company product to be free from defects in material and workmanship under normal use and service, when properly installed, used and maintained, for 1) Standard Warranty - a period of one year from date of installation or 18 months from date of manufacturer, whichever comes first OR 2) Optional Three (3) Year Warranty - a period of three (3) years from date of installation or 42 months from date of manufacturer whichever comes first. Parts that fail, (within standard or three (3) year optional warranty) that inspections determine to be defective in material or workmanship, will be repaired, replaced or remanufactured at Zoeller Pump Company's option, provided however, that by so doing we will not be obligated to replace an entire assembly, the entire mechanism or the complete unit. No allowance will be made for shipping charges, damages, labor or other charges that may occur due to product failure, repair or replacement.

This warranty does not apply to any material that has been disassembled without prior approval of Zoeller Pump Company, subjected to misuse, misapplication, neglect, alteration, accident or act of God; that has not been installed, operated or maintained in accordance with Zoeller Pump Company installation instructions; that has been exposed to but not limited to the following: sand, gravel, cement, mud, tar, hydrocarbons or hydrocarbon derivatives (oil, gasoline, solvents, etc),

wash towels or feminine sanitary products, etc. or other abrasive or corrosive substances. This warranty is in lieu of all other warranties expressed or implied; and we do not authorize any representative or other person to assume for us any other liability in connection with our products.

Contact Zoeller Pump Company, 3649 Cane Run Road, Louisville, Kentucky 40211-1961, Attention: Customer Service Department to obtain any needed repair or replacement of part(s) or additional information pertaining to our warranty.

ZOELLER PUMP COMPANY EXPRESSLY DISCLAIMS LIABILITY FOR SPECIAL, CONSEQUENTIAL OR INCIDENTAL DAMAGES OR BREACH OF EXPRESSED OR IMPLIED WARRANTY; AND ANY IMPLIED WARRANTY OF FITNESS FOR A PARTICULAR PURPOSE AND OF MERCHANTABILITY SHALL BE LIMITED TO THE DURATION OF THE EXPRESSED WARRANTY.

Some states do not allow limitations on the duration of an implied warranty, so the above limitation may not apply to you. Some states do not allow the exclusion or limitation of incidental or consequential damages, so the above limitation or exclusion may not apply to you.

This warranty gives you specific legal rights and you may also have other rights which vary from state to state.

CENTRIFUGAL PUMP REPAIR PARTS 300 SERIES (For Pricing Refer To Repair Parts Price List)

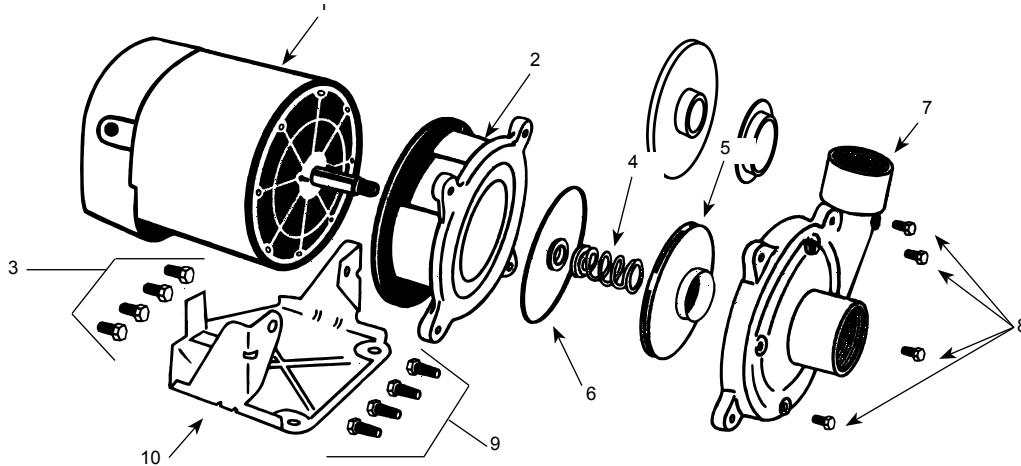

SINGLE PHASE		HORSEPOWER	1/3	1/2	3/4	1	1-1/2	2
		STAGE	1	1	1	1	1	1
ITEM	DESCRIPTION	MODEL NO.	300-0006	301-0006	302-0006	303-0006	304-0006	305-0006
		QTY.	PART NO.					
1	Motor, Nema J - 1PH	1	96J103	96J105	96J107	96J110	96J115	96J120
‡	Motor Access Cover	1	021301R	021301R	021301R	021301R	021301R	021301R
	Screws, Access Cover	2	021302	021302	021302	021302	021302	021302I
‡	Slinger Washer	1	126905	126905	126905	126905	126905	126905
2	Mounting Ring	1	020290	020290	020290	020290	020290	020290
3	Hex Hd. Cap Screws 3/8 x 3/4"	4	*	*	*	*	*	*
4	Seal, Rotary w/Spring	1	131100	131100	131100	131100	131100	131100
5	Impeller	1	130403	126900	127805	127804	127806	127848
6	Ring, Square Cut †	1	132583	132583	132583	132583	132583	132583
7	Body Assembly	1	020288	020288	020289	020289	020289	020289
‡	Suction Clearance Ring	1	127869	127869	125842	125842	125842	125842
8	Pipe Plugs, 1/8" NPT	4						
9	Hex Hd. Cap Screws 3/8 x 1"	4	*	*	*	*	*	*
10	Base	1	125855	125855	125855	125855	125855	125855

(*) Standard hardware item (‡) Not shown (†) For pumps with paper gasket, replace with part number 127782

(Δ) Kit includes: Access cover, screws & wiring diagrams

Dimensions (In Inches)										Chart A
HP	A	B	C	D	E	F	G	H	J	K
1/3	4	4-5/8	3-11/16	4-13/16	9-3/16	2-1/8	8-1/4	8-1/8	13-1/4	3-7/8
1/2	4	4-5/8	3-11/16	4-13/16	9-3/16	2-1/8	8-1/4	8-1/8	13-1/2	3-7/8
3/4	4	4-5/8	3-11/16	4-13/16	9-3/16	2-1/8	8-1/4	8-1/8	14	3-7/8
1	4	4-5/8	3-11/16	4-13/16	9-3/16	2-1/8	8-1/4	8-1/8	14-1/2	3-7/8
1-1/2	4	4-5/8	3-11/16	4-13/16	9-3/16	2-1/8	8-1/4	8-1/8	15-1/8	3-7/8
2	4	4-5/8	3-11/16	4-13/16	9-3/16	2-1/8	8-1/4	8-1/8	15-5/8	3-7/8

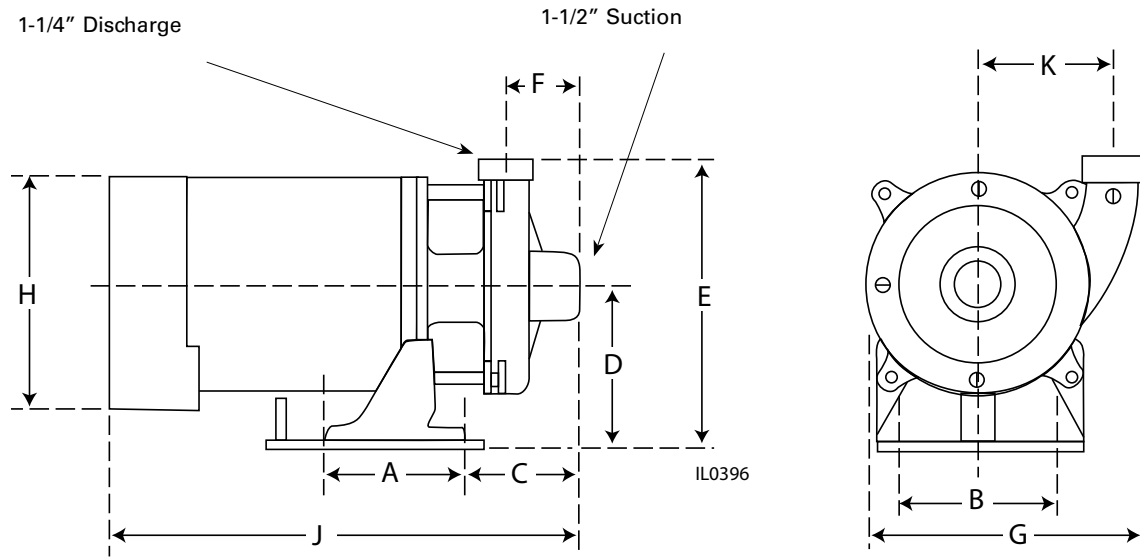

Figure 1 - 300 Series Single Stage Booster Pump

Motor Data						Chart B				
HP	PH	VOLTS	HZ	RPM	MOTOR VOLTAGE (FACTORY) CONNECT.	SERVICE FACTOR MOTOR AMPS SINGLE PHASE		LOCKED ROTOR AMPS SINGLE PHASE		KVA
						115V	230v	115V	230v	
1/3	1	115/230	60	3450	115V	8.6	4.3	26.0	13.0	K
1/2	1	115/230	60	3450	115V	13.0	6.5	36.0	18.0	K
3/4	1	115/230	60	3450	115V	14.0	7.0	52.0	26.0	K
1	1	115/230	60	3450	230V	18.0	9.0	70.0	39.0	L
1-1/2	1	115/230	60	3450	230V	21.0	10.5	98.0	49.0	J
2	1	115/230	60	3450	230V	25.0	12.5	116.0	58.0	H

Typical Installations

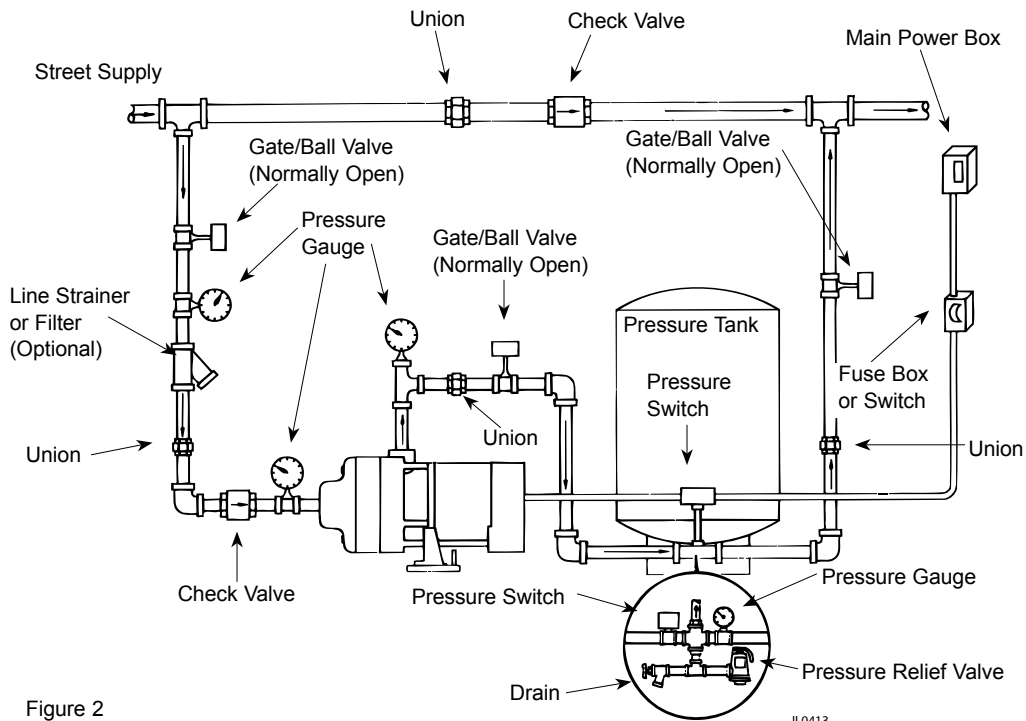

Figure 2

IL0413

To size pressure tank properly, match the drawdown of the tank to the capacity of the pump.

(*) For manual operation, omit the pressure tank and pressure switch. Wire motor direct to fuse box or switch per NEC.

⚠ WARNING *Install a pressure relief valve on any installation where pump pressure can exceed the pressure tank's maximum working pressure or on systems where the discharge line can be shut off or obstructed. Extreme over pressure can result in personal injury or property damage.*

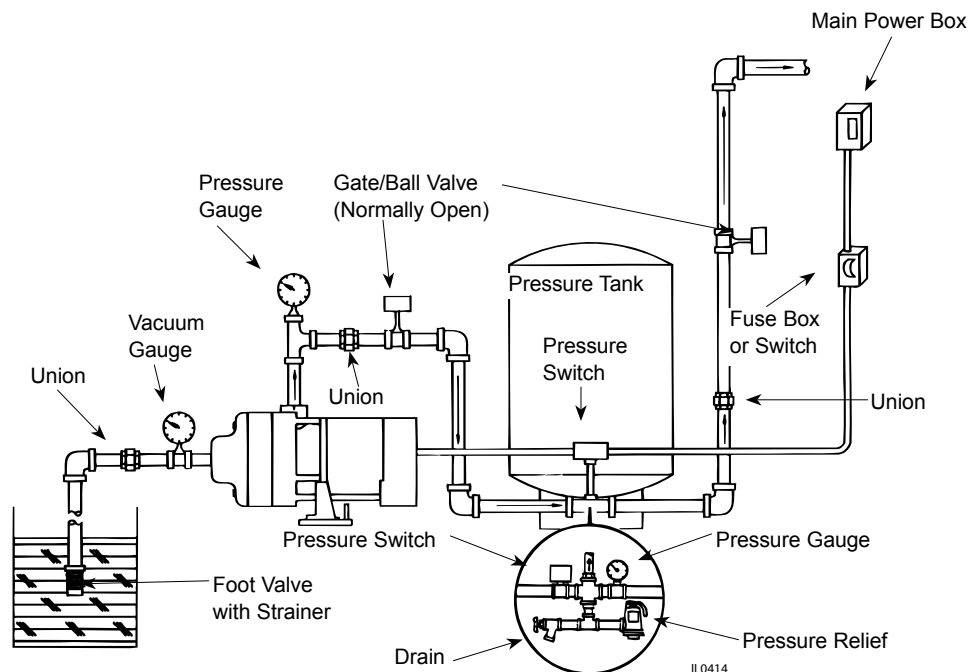

Figure 3

IL0414

Pump Performance

Chart C

Model	HP	Stage	GPM at Total Pressure in PSI					▲Max Pressure PSI	†Max Pressure PSI	‡Max Liquid Temperature
			15	20	25	30	40			
300	1/3	1	41	30	10	--	--	27	100	200°F
301	1/2	1	48	40	27	--	--	30	100	200°F
302	3/4	1	62	58	46	31	--	33	100	200°F
303	1	1	70	66	58	48	--	40	100	200°F
304	1-1/2	1	*	75	70	61	36	44	100	200°F
305	2	1	*	*	79	77	57	45	100	200°F

- (▲) Shut-off. To convert to feet of head, multiply by 2.31.
- (†) Do not exceed the maximum case pressure and maximum liquid temperature rating of the pump.
- (*) Operation of pump in this range may result in reduced pump life and/or motor damage.

INSPECTION AND STORAGE

When unpacking the unit, inspect carefully for any damage that may have occurred during shipment. If the unit is received sometime before it can be used, it should be inspected, reboxed and stored in a dry location.

LOCATION

IMPORTANT: In installations where property damage might result from an inoperative or leaking pump due to power outages, discharge line blockage or any other reason, a back-up system (s) and/or warning system(s) should be used. Install a gate valve and union in the suction and discharge lines. For removal of the pump for service, close the gate valve and disconnect the union.

1. Locate pump as close to the fluid source as possible.
2. Place unit where the motor electrical components and piping are protected from the weather and extremes of heat, humidity and below freezing temperatures.
3. Mount unit in a dry location that is easily accessible for inspection and maintenance. If a dry location is not available, mount it on a foundation well above the wet floor.
4. Allow ample clearance around unit for free air circulation.
5. Pumps incorporate a discharge port on the pump casing that can be adjusted in 90° increments. If necessary, adjust the discharge port to accommodate the specific application. Pump performance will not be affected by the position of the discharge port.

SUCTION LIMITATIONS

1. Units are not self-priming. Normally after being primed the total suction lift of the pump is 25 feet. Suction lift varies depending upon elevation

(altitude) and water temperature. See Practical Suction Lift chart.

2. Where liquids at or near their boiling points are being handled, the supply must be located above the suction, so that the available NPSH will be greater than that required by the unit.

Altitude	60°	80°	100°	120°	140°	160°	180°	200°
Sea Level	-22	-21	-20	-18	-15	-10	-4	+5
2000	-20	-19	-18	-16	-12	-7	-1	+8
4000	-17	-16	-15	-13	-10	-4	+2	+12
6000	-15	-14	-13	-11	-7	-2	+6	+16
8000	-13	-12	-10	-8	-4	+2	+9	—
10000	-10	-9	-8	-6	-2	+4	+13	—

This table gives the maximum permissible suction lift or the minimum head permitted on the suction side of a pump at various altitudes and liquid temperatures. A minus sign before a number indicates suction lift. A plus sign before a number indicates minimum head. These figures are to be used as a guide.

PIPING

1. Use galvanized piping, rigid plastic or other suitable pipe that will not collapse under suction or rupture due to pressure.
2. The diameter of the suction and discharge pipe should be no smaller than the corresponding tapings of the pump (see Figure 1). If long runs are encountered larger pipe should be used. Smaller pipe will reduce the capacity of the pump.
3. All joints and connections should have Teflon tape or pipe sealing compound (male threads only) applied and drawn up tightly.

The entire system must be air and water tight for efficient operation.

PUMP INSTALLATION

Refer to Figures 2, 3 and 4 for typical installations. Both the suction and discharge pipe should be supported at a point near the pump to avoid strains being placed on the pump.

1. If the pump is used as part of a permanent installation, secure to a rigid foundation with appropriate fasteners.
2. Locate the pump as close to the water source as possible, keeping the suction pipe as short as conditions permit.
3. Avoid dips or pockets in offset piping or air will accumulate at high points which will make priming difficult.
4. The suction pipe should slope upward to the pump inlet. A horizontal suction line must have a gradual rise to the pump.

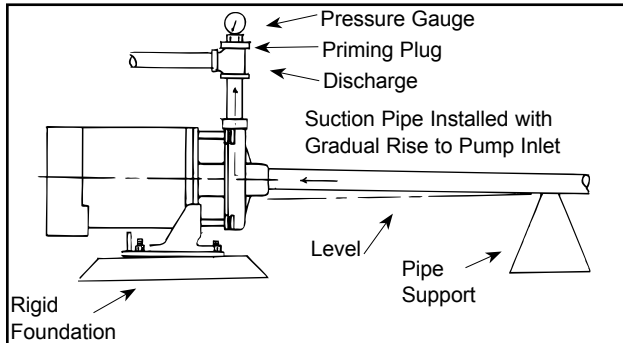

Figure 4

5. On suction lift installations, a foot valve located in the water or a check valve located as close to the water as possible will reduce priming time of the pump and help maintain prime. A strainer that will pass 3/32" to 1/8" max. diameter particles must be used on the suction line to filter out dirt and debris.
6. A priming tee installed in the pump discharge port allows water to be poured into the pump case and suction piping, which is required for priming on suction lift installations.
7. Install a gate valve and union in the suction and discharge lines. For removal of the pump for service, close the gate valve and disconnect the union.

CAUTION Do not use a globe valve or other restricting type of valve at the discharge. This will seriously restrict the capacity of the pump.

8. Pressure Gauges - Properly sized vacuum or pressure gauges can be installed in both the suction and discharge pipe. The gauges will enable observation of the pump's performance as well as detecting cavitation, vapor binding or other unstable operation.

CAUTION Use only components that are rated higher than shut-off pressure of the system. Do not exceed the pump's maximum case pressure of 100 PSI.

WARNING A pressure relief valve of adequate capacity must be installed on any installation where the pump pressure can exceed the pressure tank's maximum working pressure or on systems where the discharge line can be shut-off or obstructed. Not providing a relief valve can cause extreme over pressure which could result in personal injury and/or property damage.

WARNING ELECTRICAL

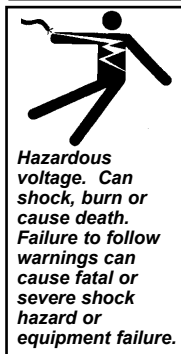

- ⚠ Ground motor before connecting to electrical power supply:
- ⚠ Connect the motor frame to equipment grounding conductor by using green screw. Do not connect green ground wire to any of the motor leads.
- ⚠ Do not ground to a gas supply line.
- ⚠ Turn off power to motor before working on electrical connections.
- ⚠ Supply voltage must be within $\pm 10\%$ of nameplate voltage when the pump is running. If in doubt consult a licensed electrician.

⚠ Use wire size specified in wiring Chart D. If wiring diagram on motor model plate differs from diagram shown in Figures 5 & 6, follow diagram on motor.

WARNING SEE CAUTIONS AND WARNINGS ON PAGE 1.

WIRING

1. Motor voltages will vary depending upon the motor horsepower and phase. Refer to the motor nameplate and the Motor Data Chart (Chart B) for voltage and electrical data.

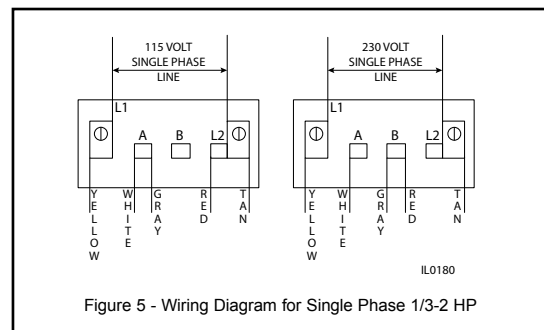

Figure 5 - Wiring Diagram for Single Phase 1/3-2 HP

2. To change voltage, remove the rear access cover, which is held in place with two (2) screws. For proper electrical connection, refer to the connection diagram located on the motor nameplate or Figure 5 above.



WARNING Replace rear access cover before starting or operating pump. Failure to do so can result in personal injury.

MOTOR PROTECTION

1. All single phase motors have built-in thermal protection for all voltages. The overload protects the motor against burnout from overload of low voltage, high voltage and other causes. The device is automatic and resets itself once the temperature has dropped to a safe point. Frequent tripping of the device indicates trouble in the motor or power lines and immediate attention is needed.
2. All motors must be equipped with a correctly protected circuit and a disconnect switch to provide protection. Consult local or national electric codes for proper fuse protection based on motor data chart (see Chart B).

**WARNING**

Never examine, make wiring changes or touch the motor before disconnecting the main electrical supply switch. The thermal device may have opened the electrical circuit.

PRIMING

1. Before starting any centrifugal pump, it is absolutely necessary that both the casing and suction pipe be completely filled with liquid. This priming can be accomplished by any of the following methods:
2. When the liquid supply level is above the center line of the pump, it is primed by opening the suction and discharge valves. The inflowing liquid will displace the air and fill the suction line, pump casing, and discharge line up to the level of supply.
3. Where the pump is operating with suction lift and the suction line is equipped with a foot valve, remove the priming plug from the discharge tee (see Figure 4) and fill the pump body and suction pipe completely with water. No additional water will be needed for subsequent start-ups unless the pump body is drained.
4. After the pump is turned on it will require 2-5 minutes before all air is evacuated from the suction line and water begins to flow. If there is no water after 5 minutes, turn the pump off and check the following:

Any air leaks on the suction line must be eliminated.

Suction pipe inlet should be a minimum of 5 feet below the water level.

Total suction lift cannot be greater than 25 feet.

Any restrictions in the discharge pipe, such as a closed valve must be eliminated.

NOTE: Unit must be full of liquid before operating. Never run dry, or against a closed discharge. Dry running or running unit against a closed discharge will cause damage to the shaft seal. Do not pump dirty water or abrasive liquids, otherwise the same may occur as if running dry.

MOTOR ROTATION

1. Pump impeller rotates in one direction only, (counterclockwise when facing the pump suction tapping) and cannot be reversed.

MAINTENANCE**Lubrication**

The pump and motor require no lubrication. The ball bearings of the motor have been greased at the factory.

Chart D

DISTANCE FROM MOTOR TO FUSE BOX METER, OR ELECTRICAL OUTLET	MINIMUM COPPER WIRE SIZE CHART (GAUGE) SINGLE PHASE MOTORS											
	1/3HP		1/2HP		3/4		1HP		1-1/2HP		2HP	
	115V	230V	115V	230V	115V	230V	115V	230V	115V	230V	115V	230V
0-50'	14	14	12	14	12	14	10	14	10	12	10	12
50-100'	14	14	12	14	12	14	10	14	8	12	8	12
100-150'	14	14	12	14	10	14	10	12	6	12	6	12
150-200'	12	14	12	14	10	12	8	12	*	10	*	10
200-300'	12	14	10	14	8	12	6	10	*	10	*	10
Breaker Size (Amps)	15	15	20	15	20	15	30	15	30	20	30	20

(*) Not economical to run in 115 volt, use 230 volts

Under normal operating conditions they should require no further greasing.

Freezing

Drain the entire system if there is danger of freezing. A drain plug is provided at the bottom of the pump case for this purpose.

ROTARY SEAL ASSEMBLY REPLACEMENT**WARNING**

Make certain that the power supply is disconnected before attempting to service the unit! The rotary seal assembly must be handled carefully to avoid damaging the precision lapped faces of the sealing components.

Disassembly

1. Remove the four (4) pump through bolts that connect the mounting ring to the pump body. Remove the pump body, taking care not to damage the gasket or o-ring.
2. Remove the impeller. Using a 9/16" open end wrench, hold the motor shaft flat and unthread the impeller by turning it counterclockwise. The motor shaft flat area is located in the middle of the mounting ring.
3. Remove the mechanical seal assembly. The rotary portion of the seal assembly (carbon ring, Buna-N gasket and spring) will easily slide off the end of the shaft. The ceramic portion can be pried out of the rubber seating using two (2) screwdrivers (see Fig. 6).

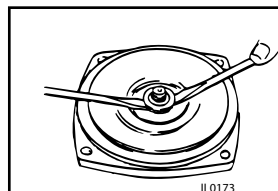

Figure 6 - Remove Mechanical Seal

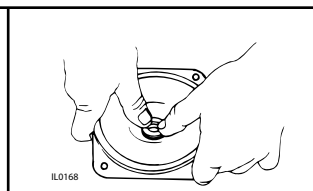

Figure 7 - Press in Seal

Reassembly

CAUTION The precision lapped faces of the mechanical seal are easily damaged. Handle the replacement seal carefully. Short seal life will result if seal faces (ceramic & carbon) are nicked, scratched or dirty.

1. Clean the seal cavity of the mounting ring and the motor shaft thoroughly.
2. Apply liquid soap (one drop only) to the outside of the Buna-N gasket that houses the ceramic seal seat. With thumb pressure, press the ceramic seat, polished face up, squarely into the seal cavity (see Figure 7).
3. If seal does not seat squarely, remove and reclean the seal cavity.

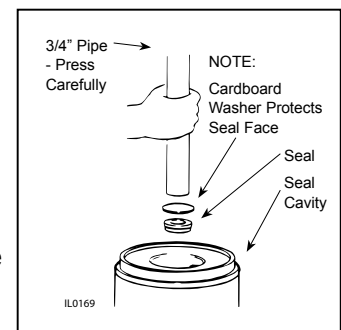

Figure 8 - If Necessary, Press with Cardboard and Pipe

Place a clean cardboard washer over the polished seal face and carefully press into place using a piece of pipe or tubing (see Figure 8). Discard cardboard washer.

4. Apply liquid soap (one drop only) to the inside diameter of the rubber drive ring. Slip rubber drive ring (carbon face down) and the spring over the shaft.
5. Reassemble the pump by following the reverse order of the disassembly instructions.

MOTOR REPLACEMENT

1. Nema J motors can be replaced in the field with any standard Nema J jet pump motor by referring to the following instructions and the attached parts list.
2. Follow steps as outlined under Rotary Seal

Replacement to remove the pump body, diffuser, impeller and rotary seal.

3. Remove bolts that connect the motor to the mounting ring and pull motor away.
4. Replace motor with standard Nema J jet pump motor by positioning motor against the mounting frame and assembling with four (4) 3/8" x 3/4" cap screws. The mounting base is connected at the bottom of the mounting frame with two (2) 3/8" x 1/2" cap screws.
5. Follow steps of Rotary Seal Assembly to reassemble the remainder of the pump.

BECAUSE DAMAGE TO THE SHAFT SEAL IS MOST LIKELY TO OCCUR IN DISASSEMBLY, A NEW SEAL IS REQUIRED.

TROUBLESHOOTING CHART

<i>Sympton</i>	<i>Possible Cause(s)</i>	<i>Corrective Action</i>
Little or no discharge	<ol style="list-style-type: none"> 1. Pump not primed 2. Total head too high 3. Suction head higher than pump designed for 4. Impeller clogged 5. Incorrect rotation 6. Leak in suction line 7. Inadequate foot valve 8. Impeller damaged 9. Foot valve or suction line not submerged deep enough in water 10. Insufficient inlet pressure or suction head source 11. Wrong size piping 12. Casing gasket leaking 13. Suction or discharge line valves closed 	<ol style="list-style-type: none"> 1. Prime unit 2. Shorten suction lift and/or discharge head 3. Lower pump inlet 4. Clean 5. Refer to wiring information 6. Repair or replace 7. Make needed adjustments 8. Replace 9. Submerge lower in water 10. Increase inlet pressure by adding more fluid to fluid 11. Make needed adjustments 12. Replace gasket 13. Open
Loss of suction	<ol style="list-style-type: none"> 1. Air leak in suction line 2. Suction head too high 3. Insufficient inlet pressure or suction head 4. Clogged foot valve or strainer 	<ol style="list-style-type: none"> 1. Repair 2. Lower pump inlet 3. Increase inlet pressure by adding more fluid to fluid source 4. Clean or replace
Pump vibrates and/or makes excessive noise	<ol style="list-style-type: none"> 1. Mounting plate or foundation not rigid enough 2. Foreign material in pump 3. Damaged impeller 4. Cavitation present 5. Worn motor bearings 6. Bent impeller shaft 	<ol style="list-style-type: none"> 1. Reinforce 2. Clean 3. Replace 4. Check suction line for proper size and be certain valve is open. Remove excessive loops in suction line 5. Replace 6. Replace
Pump will not start or run	<ol style="list-style-type: none"> 1. Improperly wired 2. Blown fuse or open circuit breaker 3. Loose or broken wiring 4. Impeller clogged 5. Motor shorted out 	<ol style="list-style-type: none"> 1. Refer to wiring diagram 2. Replace fuse or close circuit breaker 3. Tighten connections and replace broken wiring 4. Clean 5. Replace
Pumps leaks at shaft	<ol style="list-style-type: none"> 1. Worn mechanical seal 2. Bent impeller shaft 	<ol style="list-style-type: none"> 1. Replace 2. Replace