

Notice to Installer: Instructions must remain with installation.

Your Peace of Mind is Our Top Priority®

SECTION: 6.10.049

FM2101

0314

Supersedes

0105

Product information presented here reflects conditions at time of publication. Consult factory regarding discrepancies or inconsistencies.



PUMP COMPANY

Zoeller Family of Water Solutions™

MAIL TO: P.O. BOX 16347 • Louisville, KY 40256-0347
SHIP TO: 3649 Cane Run Road • Louisville, KY 40211-1961
(502) 778-2731 • 1 (800) 928-PUMP • FAX (502) 774-3624

visit our web site:
www.zoeller.com









INSTALLATION INSTRUCTIONS 330 Series Centrifugal, Lawn Sprinkler Pumps

PREINSTALLATION CHECKLIST - ALL INSTALLATIONS

1. Inspect all materials. Occasionally, products are damaged during shipment. If the unit is damaged, contact your dealer before using.
2. Carefully read all the literature provided to familiarize yourself with specific details regarding installation and use before attempting the installation. These materials should be retained for future reference.

⚠ WARNING

SEE BELOW FOR LIST OF WARNINGS

1.  To help reduce the risk of electrical shock, a proper ground or control box of grounding type must be installed and protected by a ground fault circuit interrupter (GFCI) in accordance with the National Electrical Code and applicable local codes.
2.  DO NOT USE AN EXTENSION CORD. Extension cords that are too long or too light do not deliver sufficient voltage to the pump motor. But more important, they could present a safety hazard if the insulation were to become damaged or the connection end were to fall into a damp or wet area.
3. Make sure the pump's electrical supply circuit is equipped with fuses or circuit breakers of proper capacity. A separate branch circuit, sized according to the National Electrical Code for the current shown on the pump name plate is recommended.
4.  TESTING FOR GROUND. As a safety measure, electrical supply should be checked for ground using an Underwriters Laboratory Listed circuit analyzer which will indicate if the power, neutral and ground wires are correctly connected. If they are not, call a qualified licensed electrician.
5.  Installation and checking of electrical circuits and hardware should only be performed by a qualified licensed electrician.
6.  FOR YOUR PROTECTION ALWAYS DISCONNECT PUMP FROM ITS POWER SOURCE BEFORE HANDLING. De-energize the circuit at the control box. If the power point is out-of-sight, lock it in the open position and tag it to prevent unexpected application of power. Failure to do so could result in fatal electrical shock.
7.  Unit must be securely and adequately electrically grounded. This can be accomplished by wiring the unit to a ground metal-clad raceway system or by using a separate ground wire connected to the bare metal of the motor frame or other suitable means.
8.  Do not put a valve in the discharge line without automatic shut-off capability. Failure to install an automatic shut-off (pressure switch and tank) can allow the pump to run at no flow causing the pumped liquid to overheat and cause steam burns.
9.  Risk of electric shock. This pump has not been investigated for use in swimming pool areas.
10. According to the state of California (Prop 65), this product contains chemicals known to the state of California to cause cancer and birth defects or other reproductive harm.

NOTE: Repair and service should be performed by an Authorized Service Station only (Consult factory).

NOTE: Pumps are designed to have a maximum static lift (suction head) of 25 feet (vertical distance from water surface to center line of pump).

NOTE: Pumps with the CSA CUS mark are tested to UL standard UL 778 and certified to CSA standard C22.2 No. 108.

⚠ CAUTION

SEE BELOW FOR LIST OF CAUTIONS

1. Check to be sure your power source is adequate to handle the amperage requirements of the motor as indicated on the pump or unit I.D. tag.
2. All plumbing (discharge and intake lines) must be installed to meet local codes.
3. Be certain the pump is completely primed before starting. Otherwise damage may occur to the seal.
4.  Be careful when touching the exterior of an operating motor - it may be hot enough to be painful or cause injury.

020293

LIMITED WARRANTY

Zoeller Pump Company warrants, to the purchaser and subsequent owner during the warranty period, every new Zoeller Pump Company product to be free from defects in material and workmanship under normal use and service, when properly installed, used and maintained, for 1) Standard Warranty - a period of one year from date of installation or 18 months from date of manufacturer, whichever comes first OR 2) Optional Three (3) Year Warranty - a period of three (3) years from date of installation or 42 months from date of manufacturer whichever comes first. Parts that fail, (within standard or three (3) year optional warranty) that inspections determine to be defective in material or workmanship, will be repaired, replaced or remanufactured at Zoeller Pump Company's option, provided however, that by so doing we will not be obligated to replace an entire assembly, the entire mechanism or the complete unit. No allowance will be made for shipping charges, damages, labor or other charges that may occur due to product failure, repair or replacement.

This warranty does not apply to any material that has been disassembled without prior approval of Zoeller Pump Company, subjected to misuse, misapplication, neglect, alteration, accident or act of God; that has not been installed, operated or maintained in accordance with Zoeller Pump Company installation instructions; that has been exposed to but not limited to the following: sand, gravel, cement, mud, tar, hydrocarbons or hydrocarbon derivatives (oil, gasoline, solvents, etc), wash towels or feminine sanitary products, etc. or other abrasive or corrosive substances.

This warranty is in lieu of all other warranties expressed or implied; and we do not authorize any representative or other person to assume for us any other liability in connection with our products.

Contact Zoeller Pump Company, 3649 Cane Run Road, Louisville, Kentucky 40211-1961, Attention: Customer Support Department to obtain any needed repair or replacement of part(s) or additional information pertaining to our warranty.

ZOELLER PUMP COMPANY EXPRESSLY DISCLAIMS LIABILITY FOR SPECIAL, CONSEQUENTIAL OR INCIDENTAL DAMAGES OR BREACH OF EXPRESSED OR IMPLIED WARRANTY; AND ANY IMPLIED WARRANTY OF FITNESS FOR A PARTICULAR PURPOSE AND OF MERCHANTABILITY SHALL BE LIMITED TO THE DURATION OF THE EXPRESSED WARRANTY.

Some states do not allow limitations on the duration of an implied warranty, so the above limitation may not apply to you. Some states do not allow the exclusion or limitation of incidental or consequential damages, so the above limitation or exclusion may not apply to you.

This warranty gives you specific legal rights and you may also have other rights which vary from state to state.

LOCATION

1. Pump can be located at the well or can be offset some distance away from the well. For best performance it should be located as close to the well as possible.
2. Location can be in the basement, a watertight pit below ground, or in a pump house above ground.
3. Ventilation and drainage must be provided to prevent damage from moisture to the motor and pressure switch.
4. The pump and all piping must be protected from freezing.
5. Pump and pipe line must be drained when not in use if there is any danger of freezing.

WELL CONDITIONS

1. Wells should be pumped clean of all sand and foreign matter before installing the pump or damage may result to the operating parts.
2. The well must be able of supplying enough water to satisfy the capacity of the pump and water needs. The water level must not draw down below the maximum rated suction lift of the pump or loss of capacity and prime will result.

SUCTION LIMITATIONS

1. Shallow well installation is satisfactory where the suction lift is less than 25 feet. Suction lift is the vertical lift plus losses due to friction
2. Suction lift varies depending upon elevation (altitude) and water temperature.

PIPING

1. Plastic or galvanized steel pipe may be used in the installation. Plastic pipe must have a minimum pressure rating 160 P.S.I. Galvanized steel pipe must be in good condition free of rust and scale.

Threads should be sharp and cleanly cut.

2. Both the suction and discharge pipe should be no smaller than the corresponding tapings of the pump (See Figure 1). If long runs are encountered larger pipe should be used. Smaller pipe will reduce the capacity of the pump.
3. All joints and connections should have pipe sealing compound (male threads only) applied and drawn up tightly. The entire system must be air and water tight for efficient operation.

PUMP INSTALLATION

1. Refer to Figures 3, 4, 5, and 6 for typical installations. If galvanized pipe is used, both the suction and discharge pipe should be supported at a point near the pump to avoid strains being placed on the pump.
2. The suction pipe should slope upwards from the water source to the pump. Locate the pump as close to the water as possible keeping the suction pipe as short as conditions permit.
3. Avoid dips or pockets in offset piping or air will accumulate at high points which will make priming difficult.
4. A foot valve located in the water or a check valve located as close to the water as possible will reduce priming time of the pump and help maintain prime. A strainer must be used on the suction line to filter out dirt and debris.
5. Install a gate valve and union in the discharge line. For removal of the pump for service, close the gate valve and disconnect the union.

CAUTION Do not use a globe valve or other restricting type of valve at the discharge. This will seriously restrict the capacity of the pump.

PUMP PERFORMANCE

Capacity U.S. Gallons Per Minute

Figure 1

Model	HP	Suction Lift Feet	Discharge Pressure (PSI)								Shut off Pressure PSI	Suction Pipe Tap	Discharge Pipe Tap
			10	15	20	25	30	35	40	45			
330-0005	3/4	5	56	48	42	37	29	21			41	2"	1-1/2"
		15	47	42	37	29	22	12			37		
		25	43	37	31	22	10				33		
331-0005	1	5	58	53	48	43	38	32	23	11	48	2"	1-1/2"
		15	53	48	45	37	31	24	12		43		
		25	48	44	38	33	25	14			39		
332-0005	1-1/2	5	78	77	74	70	62	53	43	30	47	2"	1-1/2"
		15	70	68	66	62	53	43	30		41		
		25	47	46	45	44	42	34			36		
333-0005	2	5	86	84	81	77	71	62	52	40	50	2"	1-1/2"
		15	76	74	72	69	64	55	43	25	45		
		25	52	51	50	47	45	42	30		40		

SPECIFICATIONS

Figure 2

HP	Type	Volts/Amps	Hz	RPM	Motor Voltage (Factory) Connected	Service Factor Motor Amps		Max Liquid Temp	Max Suction Lift
						Single	Phase		
3/4	Single Ph	115/230	60	3450	115V	14.0	7.0	180°F	25 ft.
1					230V	18.0	9.0		
1-1/2					21.0	10.5			
2					25.0	12.5			

Suction lift varies, depending upon elevation (altitude) and water temperatures.

TYPICAL INSTALLATIONS

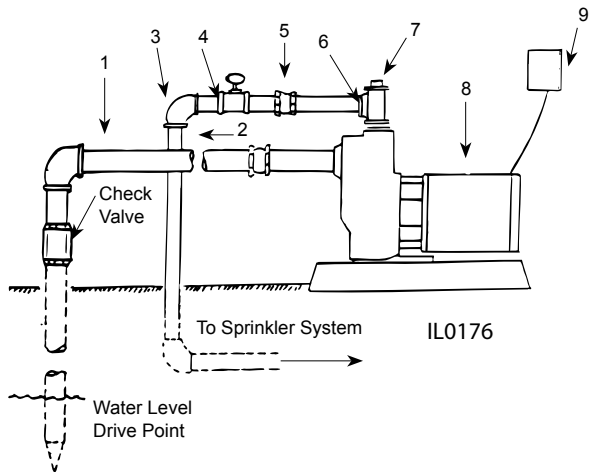

Figure 3 — From Ground Water "Drive Point"

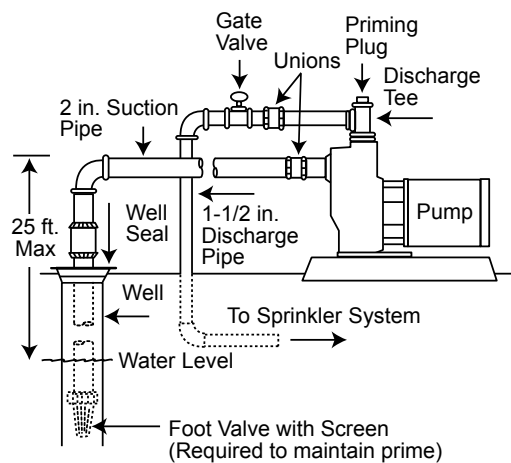

Figure 4 — From Ground Water "Well"

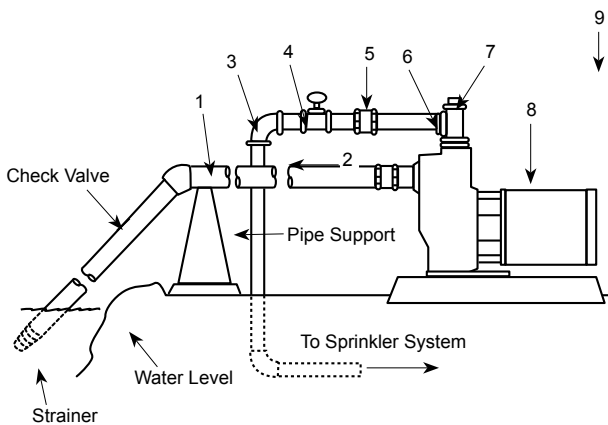

Figure 5 — From Surface Water "Lake, Stream, Cistern or Canal"

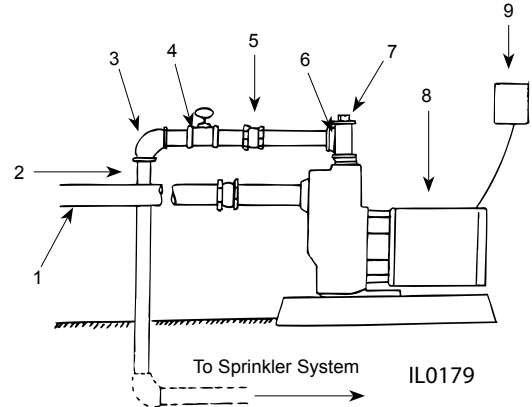

Figure 6 — From City Water Main

1 — Suction Pipe	2 — Discharge Pipe	3 — Elbow	4 — Gate Valve	5 — Union
6 — Discharge Tee	7 — Priming Plug	8 — Pump	9 — Fuse Box	

Automatic Shut-Off

⚠ WARNING

A pressure switch must be used to provide automatic shut-off when the pump is operating unattended, use the following illustration as a guideline for installing a pressure tank and pressure switch.

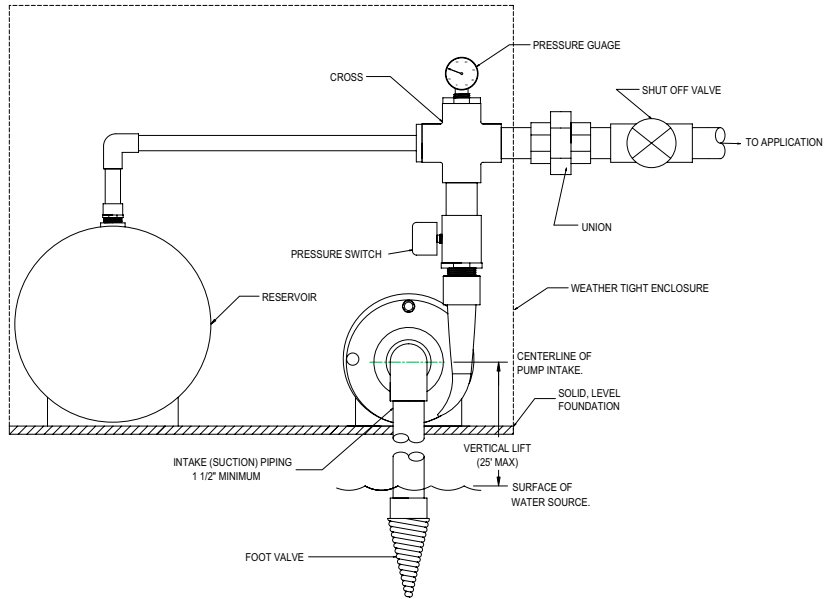

SK1981

ELECTRICAL CONNECTIONS

GROUNDING



⚠ WARNING

To reduce the risk of electric shock the motor must be securely and adequately grounded to a grounded metal race-way system, or by using a separate grounding wire connected to bare metal on the motor frame, or to the grounding screw located inside motor terminal box, or other suitable means. Refer to National Electric Code (NEC Article 250 {Grounding}) for additional information.)



⚠ WARNING

All wiring should be performed by a qualified electrician and in accordance with the national electric code and local electric codes.



⚠ WARNING

Failure to connect the motor frame to equipment grounding conductor by using green screw may result in serious electrical shock.

WIRING CONNECTIONS

1. This unit is not water proof and is not intended to be used in showers, saunas, or other potentially wet locations. The motor is designed to be used in a clean dry location with access to an adequate supply of cooling air. Ambient temperature around the motor should not exceed 104F (40C). For outdoor installations motor must be protected by a cover that does not block airflow to and around the motor. This unit is not weatherproof nor is it able to be submersed in water, or any other liquid.
2. Single phase motors, 3/4 - 2 HP, are dual voltage and can be connected for 115V or 230V service.
3. If the motor wiring must be changed to conform to your specific voltage requirements then the motor should be rewired. For proper electrical connections, refer to the connection diagram located on the nameplate of the motor or the one in Figure 7. Make sure connections are correct for the voltage being supplied to the motor.

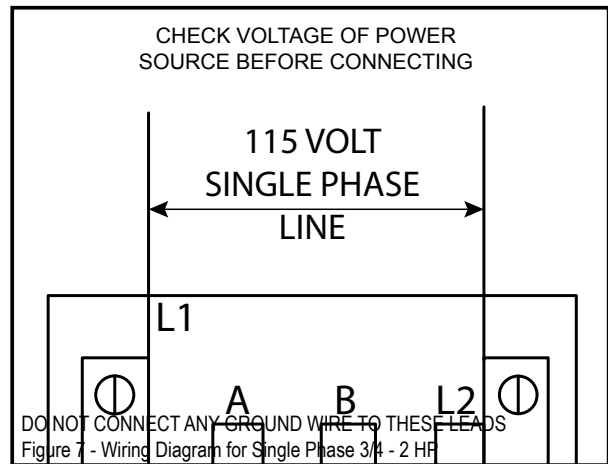

MOTOR PROTECTION

1. All motors have built-in thermal protection for all voltages. The overload protects the motor against burnout from overload of low voltage, high voltage and other causes. The device is automatic and resets itself once the temperature has dropped to a safe point. Frequent tripping of the device indicates trouble in the motor or power lines and immediate attention is needed. The device should never be tampered with unless the trouble is located and corrected.
2. Undersize wiring can cause motor failure (low voltage), frequent cut-out of motor overload protector, television interference and even fire. Make certain the wiring is adequately sized (Figure 9), well insulated and connected to a separate circuit outside the house in case of fire.

MOTOR DATA					Figure 8
HP	Phase	Volts	Code Letter	Max. Amps	Locked Rotor Amps
3/4	1	115	K	14.00	52.0
3/4	1	230	K	7.00	26.0
1	1	115	L	18.00	70.0
1	1	230	L	9.00	39.0
1-1/2	1	115	J	21.00	98.0
1-1/2	1	230	J	10.50	49.0
2	1	115	H	25.00	116.0
2	1	230	H	12.50	58.0

OPERATION

- When installation has been completed remove the priming plug from the discharge tee (see Figures 3-6) and fill the pump body and suction pipe completely with water. No additional water will be needed for subsequent start-ups unless the pump body is drained.

WIRE SIZE CHART									Figure 9
Distance From Motor To Fuse Box, Meter or Electrical Outlet	Minimum Copper Wire Size Chart (Gauge)								
	Single Phase Motors								
	3/4 HP		1 HP		1-1/2 HP		2 HP		
	115 Volt	230 Volt	115 Volt	230 Volt	115 Volt	230 Volt	115 Volt	230 Volt	
0-50 Ft.	12	14	10	14	10	12	10	12	
50-100 Ft.	12	14	10	14	8	12	8	12	
100-150 Ft.	10	14	10	12	6	12	6	12	
150-200 Ft.	10	12	8	12	*	10	*	10	
200-300 Ft.	8	12	6	10	*	10	*	10	
Fuse Size (Amps)	20	15	30	15	30	20	30	20	

(* Not economical to run in 115V, use 230V)

- After the pump is turned on it will require 2-5 minutes before all air is evacuated from the suction line and water begins to flow. If there is no water after 10 minutes turn the pump off and check the following.
 - Any air leaks on the suction line must be eliminated.
 - Suction pipe inlet should be a minimum of 5 feet below the water level.
 - Total suction lift cannot be greater than 25 feet.
 - Any restrictions in the discharge line, such as a closed valve must be eliminated.

NOTE: Unit must be full of liquid before operating. Never run dry, or against a closed discharge. Dry running or running unit against a closed discharge will cause damage to the shaft seal. Do not pump dirty water or abrasive liquids, otherwise the same may occur as if running dry.

MOTOR ROTATION

Pumps are designed to rotate in one direction only, (counterclockwise when facing the pump suction tapping) and cannot be reversed.

MAINTENANCE

Lubrication

The pumps and motors require no lubrication. The ball bearings of the motor have been greased at the factory. Under normal operating conditions they should require no further greasing.

Freezing

Drain the entire system if there is danger of freezing. A drain plug is provided at the bottom of the pump case for this purpose.

ROTARY SEAL ASSEMBLY REPLACEMENT



WARNING Make certain that the power supply is disconnected before attempting to service the unit!

CAUTION The rotary seal assembly must be handled carefully to avoid damaging the precision lapped faces of the sealing components.

See Parts List For Reference Numbers

- Disengage pump body (Ref. No. 10) from motor and mounting ring (Ref. No. 2) by removing bolts (Ref. No. 11).
- Remove diffuser bolts (Ref. No. 8) and remove diffuser (Ref. No. 7).
- Unthread impeller (Ref. No. 6), from motor shaft.

NOTE: To remove the impeller use a 9/16" open end wrench to hold the motor shaft. The shaft flat area is located in the middle of the mounting ring.

- The rotary seal (Ref. No. 5) will come loose at this time. Use a screwdriver (or similar instrument) to pry the ceramic seal and rubber gasket from the recess of the mounting bracket.

CAUTION Be careful not to damage the motor shaft or recess surface.

- Clean the recess and motor shaft thoroughly.
 - Install the new rotary seal assembly:
 - Insert the ceramic seal and the rubber gasket into the recess.
- NOTE: To help facilitate installation, apply a light coating of oil to the outside diameter of the rubber gasket. Make certain that the ceramic seal is kept clean and free of dirt and/or oil.
- Slip the remaining parts of the rotary seal assembly onto the motor shaft.
- Replace the impeller and diffuser removed in Step B and C.
 - Reassemble the pump body to the motor and mounting bracket.

MOTOR REPLACEMENT

- NEMA J motors can be replaced in the field with any standard NEMA J jet pump motor by referring to the following instructions and the attached parts list.
- Follow steps A-D as outlined under rotary seal replacement to remove the pump body, diffuser, impeller and rotary seal.
- Remove bolts (Ref. No. 3) that connect the motor (Ref. No.1) to the mounting ring (Ref. No. 2) and pull motor away.
- Replace motor with standard NEMA J jet pump motor by positioning motor against the mounting frame and assembling with four 3/8" x 3/4" cap screws. The mounting base is connected at the bottom of the mounting frame with two 3/8" x 1/2" cap screws.
- Follow steps E,F,G & H of Rotary Seal Assembly to reassemble the remainder of the pump.

NOTE: Because damage to the shaft seal is most likely to occur in disassembly, a new seal is required.

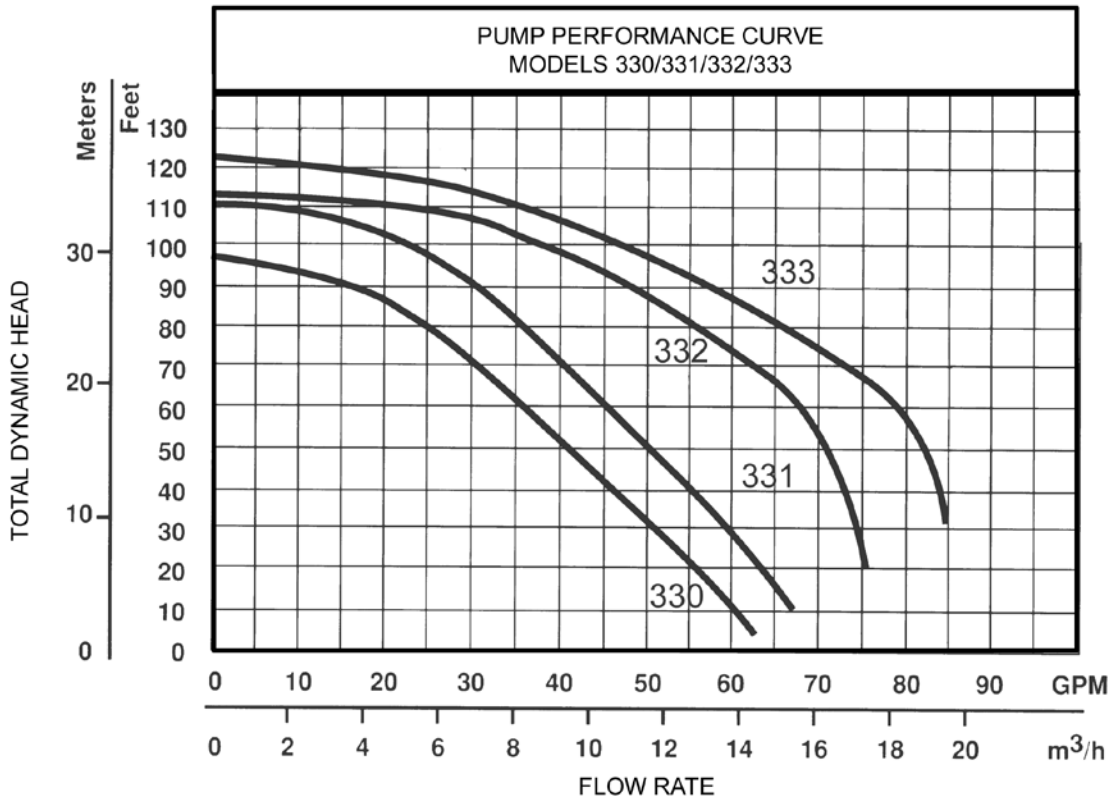

		MODEL	330-0006	331-0006	332-0006	333-0006
		HP	3/4	1	1-1/2	2
ITEM	DESCRIPTION	PART NO.		QTY.		
1	Motor, Nema J - 1 PH		96J107	96J110	96J115	96J120
	Motor Access Cover Kit◆	021301R	1	1	1	1
▲	Screws, Access Cover	136133	2	2	2	2
▲	Slinger, Washer	126905	1	1	1	1
2	Mounting Ring	020292	1	1	1	1
3	Hex Hd. Cap Screws 3/8" x 3/4"	*	4	4	4	4
4	Ring, Square Cut	133261	1	1	1	1
5	Seal, Rotary w/Spring	131100	1	1	1	1
6	Impeller, Plastic "P" Models		133646	135620	134794	----
6	Impeller, Brass "B" Models		----	----	----	133255
7	Diffuser	136469	1	1	1	1
8	Hex Hd. Cap Screws 1/4 x 1"	*	2	2	2	2
9	Rubber Diffuser	133260	1	1	1	1
10	Pump Body	020291	1	1	1	1
11	Hex Hd. Cap Screws 7/16 x 1"	*	4	4	4	4
12	Base	134217	1	1	1	1
13	Hex Hd. Cap Screws 3/8 x 1/2"	*	2	2	2	2

(*) Standard Hardware Item (▲) Not Shown (◆)Motor Access Cover Kit Includes: Access Cover, Screws, Wiring Diagram

SELF-PRIMER PUMP REPAIR PARTS — 330 SERIES

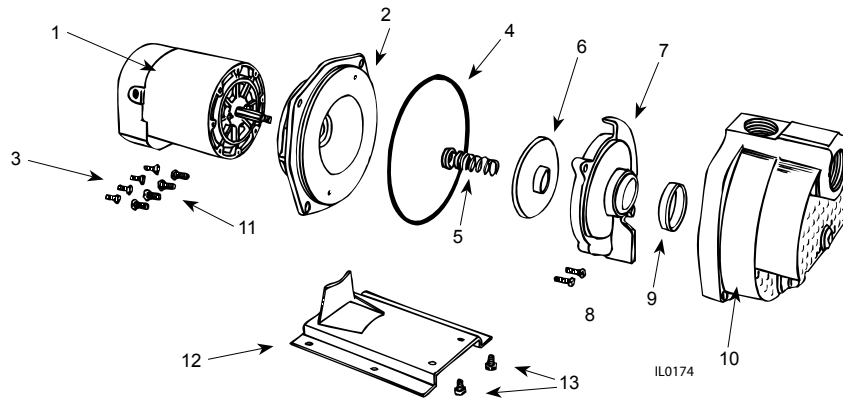

TROUBLESHOOTING CHART

Symptom	Possible Cause(s)	Corrective Action
Little or no discharge	<ol style="list-style-type: none"> 1. Casing not initially filled with water 2. Total head too high 3. Suction lift too high, or too long 4. Impeller clogged 5. Hole or air leak in suction line 6. Foot valve too small 7. Impeller damaged 8. Foot valve or suction line not submerged deep enough in water 9. Insufficient inlet pressure or suction head source 10. Suction piping too small 11. Motor wired incorrectly 12. Casing gasket leaking 13. Suction or discharge line valves closed 	<ol style="list-style-type: none"> 1. Fill pump casing 2. Shorten suction lift and/or discharge head 3. Lower suction lift, install foot valve and prime, or shorten length of suction line 4. Clean 5. Repair or replace; do not use Teflon tape; use pipe sealing compound 7. Match foot valve to piping or install one size larger foot valve 7. Replace 8. Submerge lower in water 9. Increase inlet pressure by adding more water to tank or increasing back pressure 10. Increase to pump inlet size or one size larger 11. Check wiring diagram 12. Replace 13. Open
Pump will not deliver water or develop pressure	<ol style="list-style-type: none"> 1. No priming water in casing 2. Mechanical seal is leaking 3. Leak in suction line 4. Discharge line is closed and priming air has nowhere to go 5. Suction line (or valve) is closed 6. Pump is down 7. Foot valve is leaking 8. Suction screen clogged 	<ol style="list-style-type: none"> 1. Fill pump casing 2. Replace (see Rotary Seal Replacement) 3. Repair or replace 4. Open 5. Open 6. Replace worn parts 7. Replace foot valve 8. Clean or replace
Loss of suction	<ol style="list-style-type: none"> 1. Air leak in suction line 2. Suction lift too high 3. Insufficient inlet pressure or suction head 4. Clogged foot valve or strainer 	<ol style="list-style-type: none"> 1. Repair or replace 2. Lower suction lift, install foot valve and prime 3. Increase inlet pressure by adding more water to tank or increasing back pressure 4. Unclog
Pump vibrates and/or makes excessive noise	<ol style="list-style-type: none"> 1. Mounting plate or foundation not rigid enough 2. Foreign material in pump 3. Impeller damaged 4. Worn motor bearings 5. Suction lift too high 	<ol style="list-style-type: none"> 1. Reinforce 2. Disassemble pump and clean 3. Replace 4. Replace 5. Lower suction lift, install foot valve and prime
Pump will not start or run	<ol style="list-style-type: none"> 1. Improperly wired 2. Blown fuse or open circuit breaker 3. Loose or broken wiring 4. Stone or foreign object lodged in impeller 5. Motor shorted out 6. Thermal overload has opened circuit 	<ol style="list-style-type: none"> 1. Check wiring diagram on motor 2. Replace fuse or close circuit breaker 3. Tighten connections and replace broken wiring 4. Disassemble pump and remove object 5. Replace 6. Allow unit to cool, restart after reason for overload has been determined
Pumps leaks at shaft	<ol style="list-style-type: none"> 1. Worn mechanical seal 	<ol style="list-style-type: none"> 1. Replace (see Rotary Seal Replacement)